

## Fast Charging Physical Layer IC for USB Interfaces

QC3.0/QC2.0,FCP,SCP,AFC,SFCP,MTK PE+ 2.0/1.1,Apple 2.4A,BC1.2

### 1. Features

- Support several charging standards including :
  - QC3.0/QC2.0, FCP, SCP, AFC, SFCP, MTK PE+ 2.0/1.1
  - Apple 2.4A and BC1.2
- Support Qualcomm® QC3.0/QC2.0 Class A
  - QC3.0 Class A: 3.6V~12V(0.2V/step)
  - QC2.0 Class A: 5V, 9V, 12V
- MTK PE+ 2.0/1.1
  - PE+ 2.0: 5V~12V(0.5V/step)
  - PE+ 1.1: 3.6~5V(0.2V/step), 7V/9V/12V
- Support Huawei® FCP of 5V and 9V
- Support Huawei® SCP: 5V/4.5A, 4.5V/5A
- Support Samsung® AFC of 5V and 9V
- Support Spreadtrum® SFCP of 5V, 9V and 12V
- Support Apple 2.4A: DP=2.7V, DM=2.7V
- Support BC1.2: DP short DM automatically
- Default 5 V mode operation
- Support auto-detect and auto-switching fast charging standards
- FB for voltage regulation
- Support DP,DM overvoltage protection
- Support DP,DM weak short to GND protection
- Support line loss compensation: 250mV/2A
- Support VCC fast discharge
- Very low power consumption  $I_Q = 130\mu A$ (Typ.)
- VCC working voltage: 3.6V~12V
- Package: SOP8

### 2. Typical Applications

- USB power output ports for AC adapters, Power Bank, Car chargers
- Battery chargers for smart phones, tablets, netbooks, digital cameras, and Bluetooth accessories

### 3. Description

IP2163H is a fast charging Physical Layer IC dedicated for USB ports, which supports several kinds of fast charging standards, including HVDCP QC3.0/QC2.0 (Quick Charge) Class A, FCP (Hisilicon® Fast Charge Protocol), SCP (Hisilicon® Super Charge Protocol) 4.5V/5A, AFC (Samsung® Adaptive Fast Charge), SFCP (Spreadtrum® Fast Charge Protocol), MTK PE+ 2.0/1.1 (MediaTek Pump Express Plus 2.0/1.1), Apple 2.4A, BC1.2.

IP2163H support automatically detecting the connected device's type and switching standards type to responding for fast charging requirements.

FB control line support sink or source current with precise 1uA/step in minimum, for accurate voltage regulation.

### 4. Publicly Model

Part Num.	Description
IP2163H	Standard model, Pin7 NC. SFCP is not supported. If SFCP is required, consult the service. OCP is not supported. If OCP is required, consult the service.
IP2163H_SEL	Pin7 is SEL function, which is used to configure the maximum voltage allotment that can be request. The maximum voltage: Float 9V, GND 12V

IP2163H_LED	Pin 7 is LED lighting function. Details are described in Chapter 10.
IP2163H_AT	Pin 1 is both CSN and NTC functions with automatic detection. Pin 2 is both CSP and FA functions with automatic detection. Details are described in Chapter 10.

## 5. Typical Application Schematic

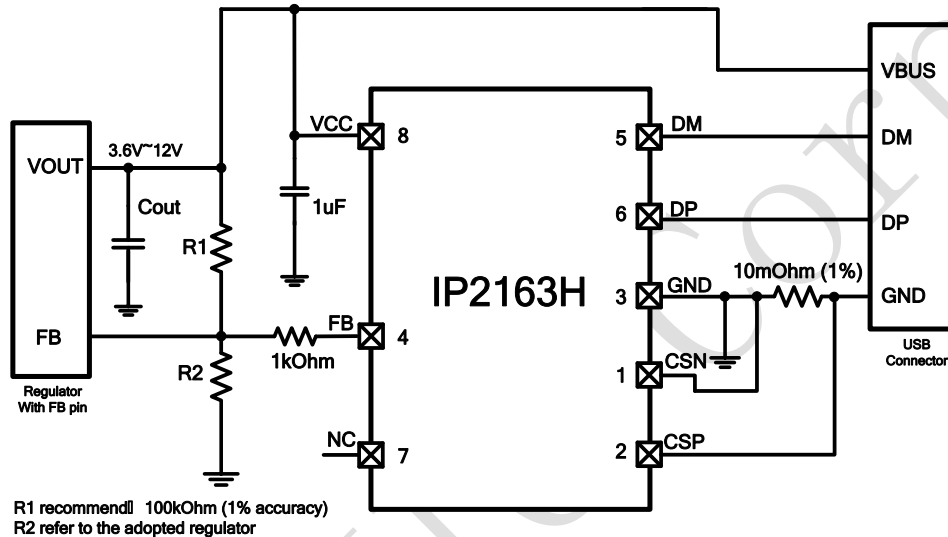

## 6. PIN Description

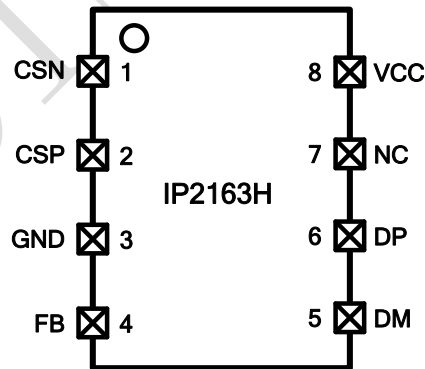

Pin No.	Pin Name	Description
1	CSN	Negative current sense node, connected to chip GND. A high-precision 10mOhm (1%) resistor needs to be connected between the chip's GND and the USB port's GND.
2	CSP	Positive current sense node, connected to USB port GND. A high-precision 10mOhm (1%) resistor needs to be connected between the chip's GND and the USB port's GND.
3	GND	Ground

4	FB	Connect to the FB line of Regulator, current source/sink for voltage regulation
5	DM	Connect to the DM pin of the USB port
6	DP	Connect to the DP pin of the USB port
7	NC	Floating
8	VCC	Power Input

## 7. Absolute Maximum Ratings

Parameters	Symbol	Value	Unit
VCC Input Voltage Range	VCC	-0.3 ~ 15	V
DP, DM Input Voltage Range	V <sub>DP</sub> , V <sub>DM</sub>	-0.3~15	V
Other Pins Input Voltage Range	V <sub>other</sub>	-0.3~6.5	V
Junction Temperature Range	T <sub>J</sub>	-40 ~ 150	°C
Storage Temperature Range	T <sub>STG</sub>	-60 ~ 150	°C
Lead Temperature Range (Soldering, 10sec)	T <sub>s</sub>	260	°C
Package Thermal Resistance	θ <sub>JA</sub>	250	°C
Package Thermal Resistance	θ <sub>JC</sub>	110	°C
Human Body Model (HBM)	ESD	4	KV

\*Stresses beyond those listed under Absolute Maximum Ratings may cause permanent damage to the device.

Exposure to Absolute Maximum Rated conditions for extended periods may affect device reliability.

\*Voltages are referenced to GND unless otherwise noted.

## 8. Recommended Operating Conditions

Parameter	Symbol	Min.	Typ.	Max.	Unit
Input Voltage	VCC	3.6		13	V
Ambient Temperature	T <sub>A</sub>	-40		85	°C

\*Devices' performance cannot be guaranteed when working beyond those Recommended Operating Conditions.

## 9. Electrical Characteristics

Unless otherwise specified, T<sub>A</sub> = 25 °C, 4.5V ≤ VCC ≤ 5.5V

Parameter	Symbol	Test Conditions	Min.	Typ.	Max.	Unit
Input Voltage	VCC	Supplied directly	3.6		13	V
Input UVLO Threshold	UVLO	VCC Falling	2.8		3.3	V

Quiescent Current	$I_q$	No load, VCC=5V		130			uA
Startup Time	$T_s$			15			ms
<b>HVDCP (QC2.0&amp;QC3.0)</b>							
Data Detect Voltage Threshold	$V_{DATA\_REF}$		0.25	0.325	0.4		V
Output Voltage Selection Reference	$V_{SEL\_REF}$		1.8	2	2.2		V
DP High Glitch Filter Time	$T_{GLITCH(BC)_{DP\_H}}$		1000	1250	1500		ms
DM Low Glitch Filter Time	$T_{GLITCH(BC)_{DM\_L}}$			2			ms
Output Voltage Glitch Filter Time	$T_{GLITCH(V)_{CHANGE}}$		20	40	60		ms
Continuous Mode Glitch Filter Time	$T_{GLITCH\_CONT\_CHANGE}$		100		200		us
DM Pull-down Resistance	$R_{DM\_DOWN}$	VDP=0.6V		20			kOhm
DP Pull-down Resistance	$R_{DAT\_LKG}$	VDP=0.6V		500			kOhm
FB Current Step	$I_{UP}, I_{DOWN}$	40uA(9V)		1			uA
<b>DCP</b>							
Apple 2.4A DP/DM Output Voltage			2.64	2.7	2.76		V
Apple 2.4A DP/DM Output Impedance				30			kOhm

## 10. Function Description

### Charging Standards

IP2163H is a highly integrated, fast charging Physical Layer IC dedicated for charging applications where charging standards required to be negotiated between USB ports. IP2163H is needed at the host-side, when the attached portable client-side device negotiate the power allotment from the power source host-side, IP2163H can auto-detect and respond to the those charging standards and may grant or deny the request based on the available voltage/current. IP2163H will inform the power source host-side to adjust the output voltage by FB line once charging request granted.

IP2163H support analysis several charging standards, including HVDCP QC3.0/QC2.0 (Quick Charge) Class A, FCP (Hisilicon® Fast Charge Protocol), SCP (Hisilicon® Super Charge Protocol) 4.5V/5A, AFC (Samsung® Adaptive Fast Charge), SFCP (Spreadtrum® Fast Charge Protocol), MTK PE+ 2.0/1.1(MediaTek Pump Express Plus 2.0/1.1), Apple® 2.4A and BC1.2.

IP2163H monitors the real-time voltage on DP line and DM line, when the attached device is not the fast

charging type, IP2163H will change the voltage on the DP, DM line to fulfill the negotiation process. When fast charging client-side device connected, IP2163H auto-detect the type of charging standard and analysis the power requirements, source/sink current on FB line to grant the request voltage. When the output voltage is default 5V, FB line neither source nor sink current. IP2163H is not in control of the charging power loop, the actual charging loop and charging current is determined by the host-side power source and the client-side USB port device.

## Power Control

IP2163H regulate the FB voltage to adjust the VBUS voltage based on the device's request.

IP2163H support power control for charging devices. For instance, when the power of the charging device exceeds the rated value, such as 18W, IP2163H will adjust the FB to lower the output voltage, thereby controlling the device's power to not exceed 18W. When the output is below 6V and the output current exceeds 3A, IP2163H will adjust the FB to keep the output current at 3A, ensuring that the device power does not exceed 18W. Additionally, when the output exceeds 6V, if the current exceeds 18W divided by the voltage, IP2163H will adjust the FB to maintain the output current multiplied by the voltage at 18W, ensuring that the device power meets the 18W requirement. When 10mohm sample resistor applied, to satisfy the 18W requirement, the actual power is limited at 22W or so. The 10mohm resistor's value can be tuned to adjust power limit point.

## SEL

IP2163H\_SEL has Pin 7 designated as the SEL function, which is used to configure the maximum voltage allotment that can be request. When SEL line is floating, the maximum voltage allotment is 9V; When SEL line is pull down to GND, the maximum voltage allotment is 12V.

SEL	Voltage
Float	9V
GND	12V

## HLED

IP2163H\_LED has Pin 7 designated as the HLED function, which is used as fast charging indicator light. When the chip enters fast charging mode, it releases a 20mA current from HLED line to illuminate the LED; when exiting fast charging mode, it stops outputting current, turning off the LED. It is recommended to connect a 100ohm resistor in series on the circuit, or adjust the resistor size as needed to regulate the brightness of the indicator light.

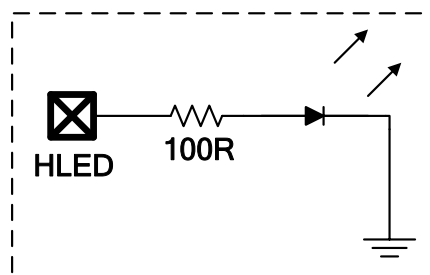

## CSN/CSP vs NTC/FA

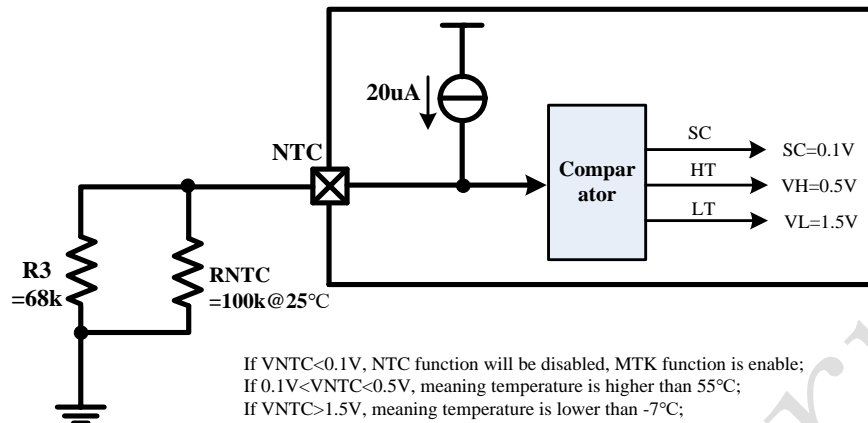

IP2163H\_AT integrates NTC temperature sensitive resistor detection, and supports abnormal temperature indication on FA pin. NTC and FA are multiplexed with CSN and CSP function on Pin 1 and Pin 2, only one function is enabled at the same time.

Automatic detection implementation: A 20uA current is released from Pin 1. When Pin 1 is grounded, an internal comparator detects the voltage at Pin 1 to be less than 0.1V, at which point Pin 1 and Pin 2 operate as CSN and CSP, deactivating the NTC and FA functions. When Pin 1 is connected to a parallel resistor R3 and RNTC thermistor to ground, Pin 1 and Pin 2 operate as NTC and FA, automatically deactivating CSN and CSP.

When selecting MTKPE+2.0/1.1, i.e., CSN/CSP function, a high-precision 10mOhm (1%) resistor needs to be connected between the chip's GND and the USB port's GND.

- 1) Pin 1 as CSN: Current detection negative pin, connected to chip GND, automatically deactivates NTC function.
- 2) Pin 2 as CSP: Current detection positive pin, connected to USB port GND, automatically deactivates FA function.

When selecting NTC/FA function, direct connection between the chip's GND and the USB port's GND is required, and there is no need for a high-precision 10mOhm (1%) resistor.

- 1) Pin 1 as NTC: Thermistor detection pin, connected to parallel resistors RNTC and R3, automatically deactivates MTKPE+2.0/1.1 function.
- 2) Pin 2 as FA: Abnormal temperature indication pin, outputs a low level of 0V when the temperature is normal, or a high level of 4V when the temperature is abnormal (too low or too high).

When detected  $V_{NTC} > V_L$  (1.5V), meaning that the temperature is lower than  $-7^{\circ}C$ , FA will output high level; when detected  $SC$  (0.1V)  $< V_{NTC} < V_H$  (0.5V), meaning that the temperature is higher than  $55^{\circ}C$ , FA will output high level; when detected  $V_H$  (0.5V)  $< V_{NTC} < V_L$  (1.5V), meaning that the temperature is in normal range of  $-7^{\circ}C \sim 55^{\circ}C$ , FA will output low level.

## FB

IP2163H integrated FB control line used for accurate voltage regulation by source/sink current with precise 1uA/step in minimum. FB sink 40uA current for 9V output voltage; when the output voltage is default 5V, FB neither source nor sink current.

In typical applications, IP2163H FB connects to the regulator's FB line, resistor (R1) between VOUT and FB

should apply 100kOhm with high precision (1%), resistor (R2) value between FB and GND should refer to the regulator adopted, resistance of R2 can be calculated by equation:

$$V_{FB} = \frac{V_{OUT}}{R1+R2} * R2$$

INJOINIC Corp.

## 11. Package

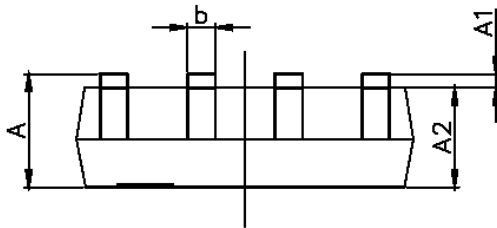
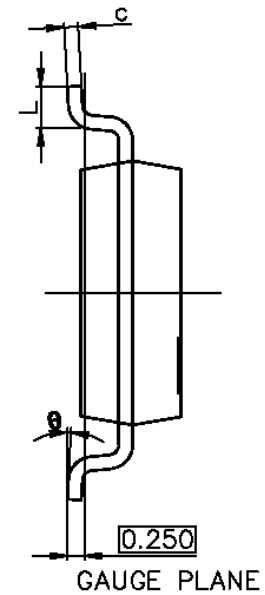
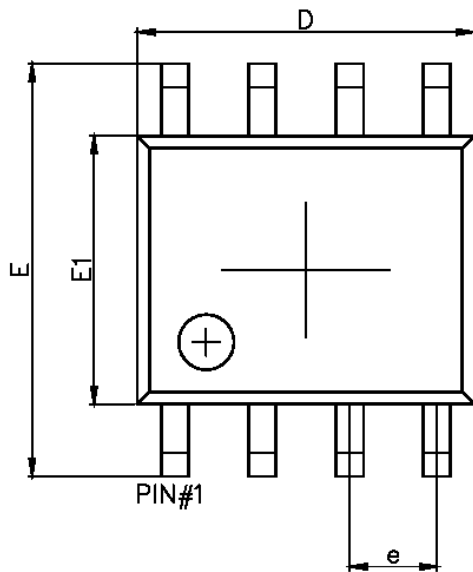

Symbol	Dimensions In Millimeters		Dimensions In Inches	
	Min.	Max.	Min.	Max.
A	1.350	1.750	0.053	0.069
A1	0.100	0.250	0.004	0.010
A2	1.350	1.550	0.053	0.061
b	0.330	0.510	0.013	0.020
c	0.170	0.250	0.007	0.010
D	4.800	5.000	0.189	0.197
e	1.270 (BSC)		0.050 (BSC)	
E	5.800	6.200	0.228	0.244
E1	3.800	4.000	0.150	0.157
L	0.400	1.270	0.016	0.050
$\theta$	0°	8°	0°	8°



## 12. IMPORTANT NOTICE

INJOINIC TECHNOLOGY and its subsidiaries reserve the right to make corrections, enhancements, improvements and other changes to its semiconductor products and services. Buyers should obtain the latest relevant information before placing orders and should verify that such information is current and complete. All semiconductor products (also referred to herein as “components”) are sold subject to INJOINIC TECHNOLOGY's terms and conditions of sale supplied at the time of order acknowledgment.

INJOINIC TECHNOLOGY assumes no liability for applications assistance or the design of Buyers' products. Buyers are responsible for their products and applications using INJOINIC TECHNOLOGY's components. To minimize the risks associated with Buyers' products and applications, Buyers should provide adequate design and operating safeguards.

Buyer acknowledges and agrees that it is solely responsible for compliance with all legal, regulatory and safety-related requirements concerning its products, and any use of INJOINIC TECHNOLOGY's components in its applications, notwithstanding any applications-related information or support that may be provided by INJOINIC TECHNOLOGY. Buyer represents and agrees that it has all the necessary expertise to create and implement safeguards which anticipate dangerous consequences of failures, monitor failures and their consequences, lessen the likelihood of failures that might cause harm and take appropriate remedial actions. Buyer will fully indemnify INJOINIC TECHNOLOGY and its representatives against any damages arising out of the use of any INJOINIC TECHNOLOGY's components in safety-critical applications.

Reproduction of significant portions of INJOINIC TECHNOLOGY's information in INJOINIC TECHNOLOGY's data books or data sheets is permissible only if reproduction is without alteration and is accompanied by all associated warranties, conditions, limitations, and notices. INJOINIC TECHNOLOGY is not responsible or liable for such altered documentation. Information of third parties may be subject to additional restrictions.

INJOINIC TECHNOLOGY will update this document from time to time. The actual parameters of the product may vary due to different models or other items. This document voids all express and any implied warranties.

Resale of INJOINIC TECHNOLOGY's components or services with statements different from or beyond the parameters stated by INJOINIC TECHNOLOGY for that component or service voids all express and any implied warranties for the associated INJOINIC TECHNOLOGY's component or service and is an unfair and deceptive business practice. INJOINIC TECHNOLOGY is not responsible or liable for any such statements.