

Fast Charging Controller IC for USB Interfaces

TypeC/PD2.0/PD3.1, QC5/QC4+/QC3+/QC3.0/QC2.0, FCP, SCP, AFC, SFCP, MTK PE+ 2.0/1.1, UFCS, Apple, BC1.2

1. Features

- **Support Charging standards including**
 - ✧ USB Type-C and USB Power Delivery
 - Type-C Source
 - Support USB PD2.0/PD3.1 SPR&EPR 36V
 - PD with EPR USB-IF TID: 9627
 - Integrated VCONN power and switch for reading E-Marker cable
 - ✧ Support QC5/QC4+/QC3+/QC3.0/QC2.0
 - Compatible with Class B
 - ✧ Support FCP/SCP
 - ✧ Support AFC
 - ✧ Support SFCP
 - ✧ Support MTK PE+ 2.0/1.1
 - ✧ Support UFCS
 - ctf. no 0302347161322ROM-UFCS00054
 - ✧ Support BC1.2, Apple 2.4A, SAMSUNG 2.0A
- **Independent built-in shunt regulator**
 - ✧ Programmable constant voltage control with minimum step of 10mV
 - ✧ Programmable constant current control with minimum step of 12.5mA
 - ✧ Integrated low side current sense amplifier
 - ✧ Cable drop compensation
- **Support multiple modes of voltage control**
 - ✧ Control of optocoupler
 - ✧ Control of I2C
- **Power management**
 - ✧ Integrated NMOS driver and support VDS detecting
 - ✧ Integrated Bleeder
 - ✧ Support power saving mode
- **Programmable fault protections**
 - ✧ Over Voltage Protection (OVP)
 - ✧ Under Voltage Protection (UVP)
 - ✧ Over Current Protection (OCP)
 - ✧ Over Temperature Protection (OTP)
 - ✧ DP/DM/CC1/CC2 over voltage protection
- **Operating voltage range: 3V~40V**
- **Package**
 - ✧ QFN24

2. Description

The IP2756 is a highly integrated fast charging controller dedicated for USB interfaces which supports many kinds of charging standards includes Type-C Source, PD2.0/PD3.1 SPR & EPR36V, HVDCP QC5/QC4+/QC3+/QC3.0/QC2.0 (Quick Charge), FCP (Hisilicon® Fast Charge Protocol), SCP (Super Fast Charge), AFC (Samsung® Adaptive Fast Charge), SFCP, MTK PE+ 2.0/1.1 (MediaTek Pump Express Plus 2.0/1.1), UFCS (Universal Fast Charging for Mobile Devices), BC1.2, Apple 2.4A, SAMSUNG 2.0A.

The IP2756 supports automatically detecting the connected device and switching standards type to respond to the fast charging requirements.

3. Applications

- USB power output ports for AC adapter, power bank, car charger, etc.
- Power supply for smart phones, tablets, netbooks, digital cameras, etc.

Contents

1. FEATURES	1
2. DESCRIPTION	1
3. APPLICATIONS	1
4. REVISION HISTORY	3
5. TYPICAL APPLICATION SCHEMATIC.....	4
6. PIN ASSIGNMENT	6
7. ABSOLUTE MAXIMUM RATINGS	8
8. RECOMMENDED OPERATING CONDITIONS.....	8
9. ELECTRICAL CHARACTERISTICS.....	9
10. PACKAGE.....	10
11. TAPE AND REEL INFORMATION	13
12. MARKING SPECIFICATION	15
13. PICTURE OF MATERIAL OBJECT	15
14. SOLDER INSTRUCTION	16
15. IMPORTANT NOTICE	17

INJOINIC CORP.

4. Revision History

NOTE: Page numbers for previous revisions may differ from page numbers in the current version.

Revision V1.00 (March 2023)

Changes from Revision V1.00 (March 2023) to Revision V1.01 (July 2023) Page

- Update PD with EPR USB-IF TID.....1
- Update the note of typical application schematic of control of optocoupler.....4
- Update the note of typical application schematic of control of I2C.....5

Changes from Revision V1.01 (July 2023) to Revision V1.02 (August 2023) Page

- Update UFCS Certificate.....1

INJOINIC CORP.

5. Typical Application Schematic

- Control of optocoupler

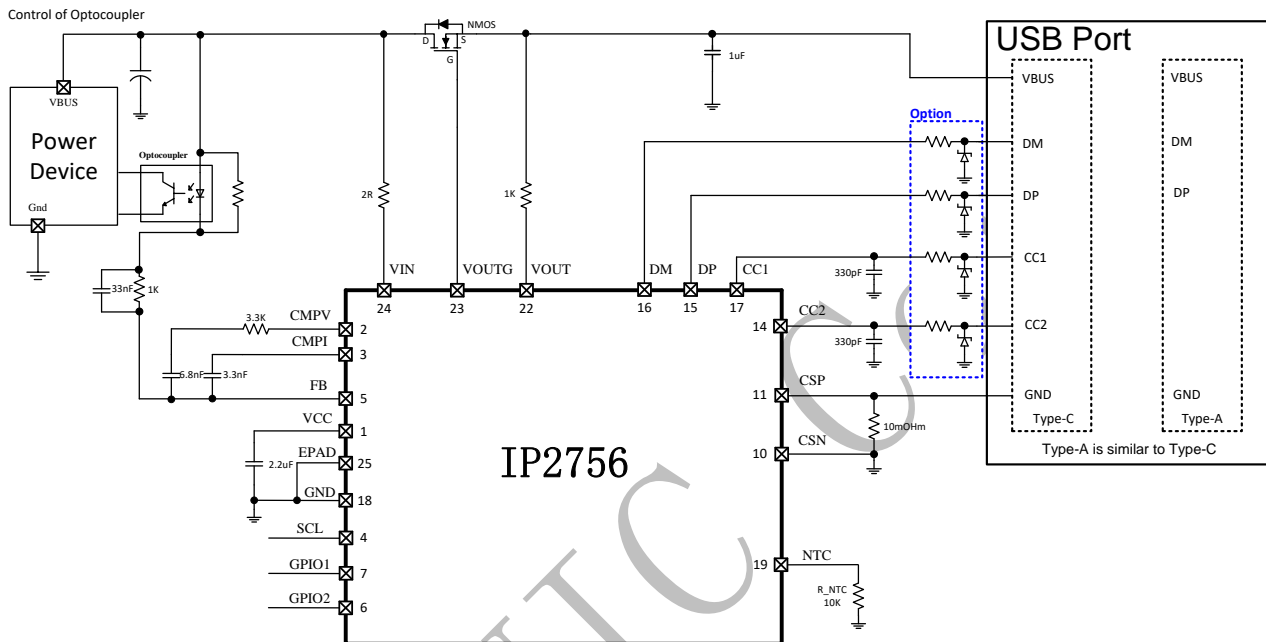

Figure 5-1. Typical application schematic of control of optocoupler

Note:

- 1). $V_{dss} \geq 30V$ NMOS (SPR) or $\geq 40V$ NMOS (EPR) is recommended;
- 2). $10k\Omega$ ($B=3380K$) NTC is recommended;
- 3). The compensation capacitor and compensation resistor of CMPV/CMPI are adjustable refer to the power device;
- 4). It is recommended to use $1k$ for $20V$ (SPR) or $510R$ for $28V$ (EPR) between VOUT and VBUS;

- Control of I2C

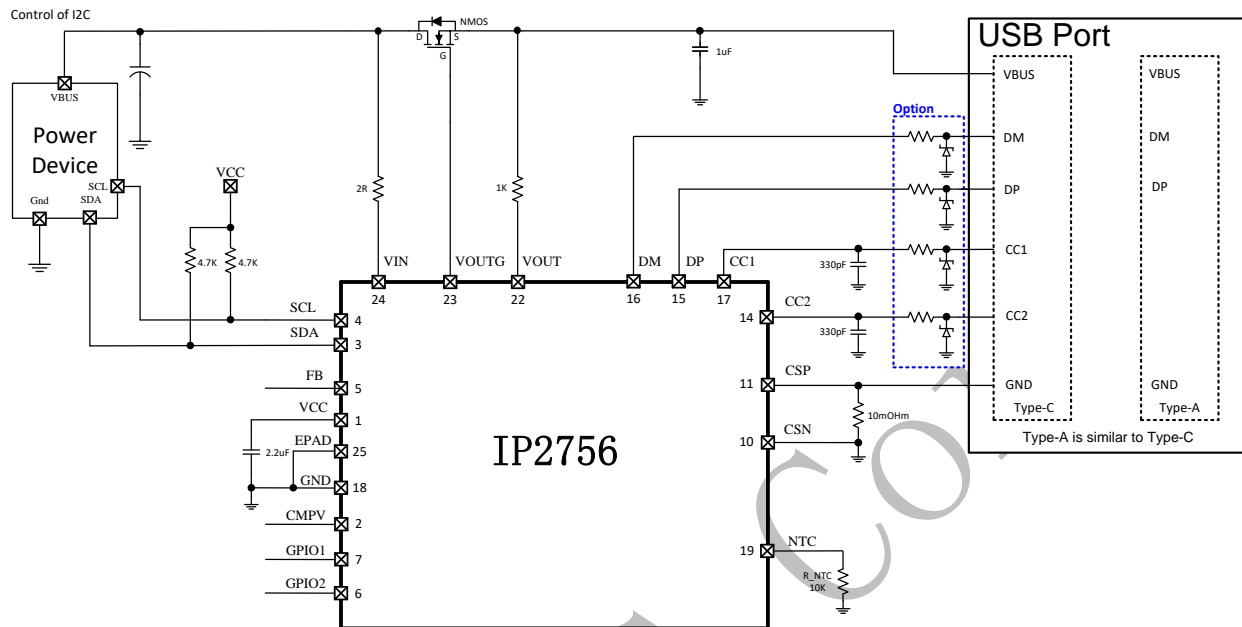

Figure 5-2. Typical application schematic of control of I2C

Note:

- 1). $V_{dss} \geq 30V$ NMOS (SPR) or $\geq 40V$ NMOS (EPR) is recommended;
- 2). 10kOhm(B=3380K) NTC is recommended;
- 3). It is recommended to use 1k for 20V(SPR) or 510R for 28V(EPR) between VOUT and VBUS;

6. Pin Assignment

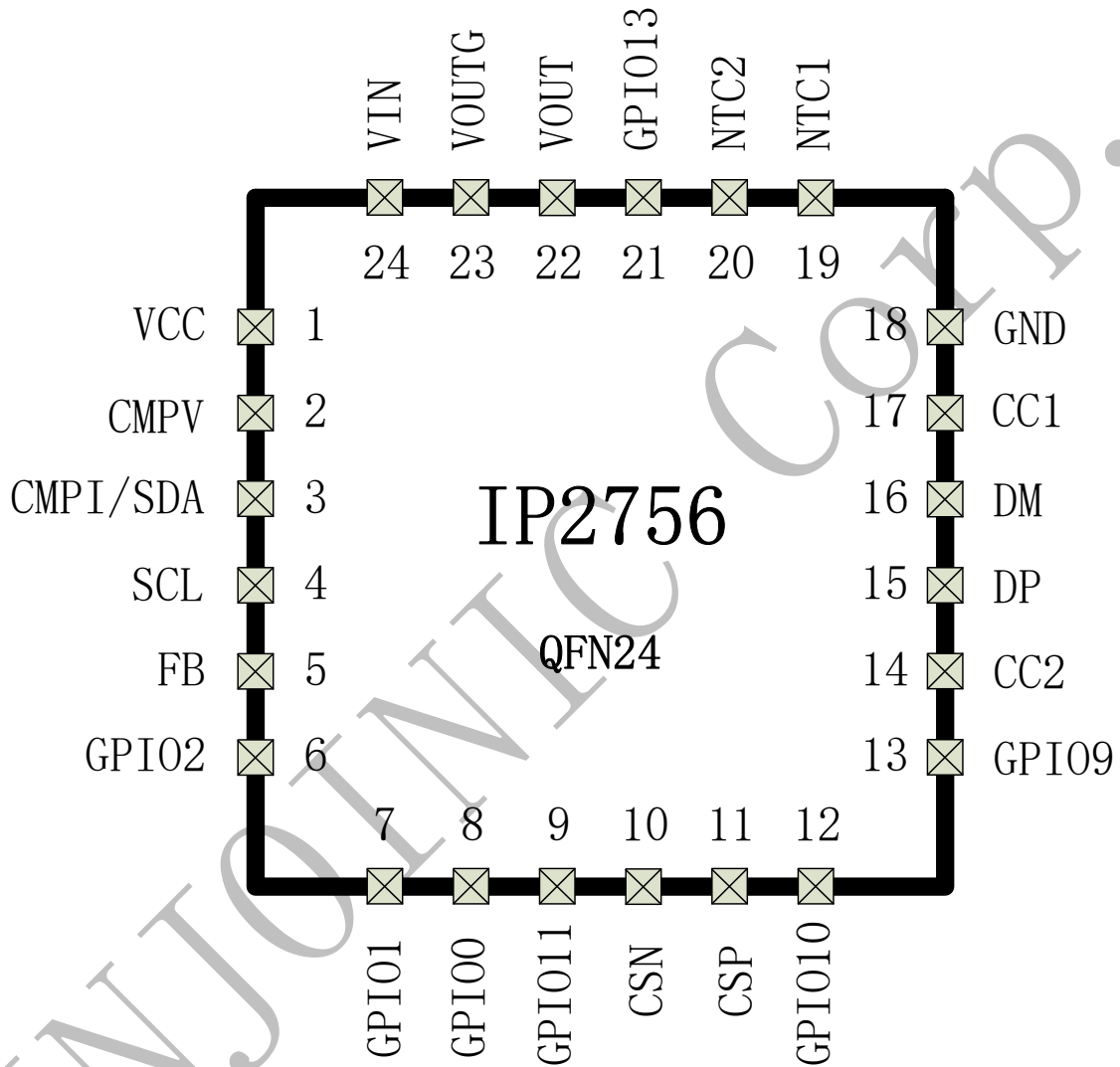

Figure 6-1. Pin Assignment (Top view)

Table 6-1. Pin Description

Pin No.	Pin name	Pin description
1	VCC	Internal power supply output, it is recommended that an external capacitance 2.2uF be used
2	CMPV	Loop compensation of voltage
3	CMPI/SDA	Loop compensation of current / I2C data
4	SCL	I2C clock, can be configured as general purpose I/O 4
5	FB	Loop feedback driver
6	GPIO2	General purpose I/O 2, can be configured as ADC
7	GPIO1	General purpose I/O 1, can be configured as ADC
8	GPIO0	General purpose I/O 0, can be configured as ADC
9	GPIO11	General purpose I/O 11, can be configured as ADC
10	CSN	Negative input of current sense amplifier
11	CSP	Positive input of current sense amplifier
12	GPIO10	General purpose I/O 10, can be configured as UART_TX
13	GPIO9	General purpose I/O 9, can be configured as UART_RX
14	CC2	Type-C Configuration Channel2
15	DP	USB DP, can be configured as UART_TX/UART_RX/GPIO
16	DM	USB DM, can be configured as UART_TX/UART_RX/GPIO
17	CC1	Type-C Configuration Channel1
18	GND	Ground
19	NTC1	NTC Resistor input for temperature sense, built-in current source
20	NTC2	NTC Resistor input for temperature sense, built-in current source
21	GPIO13	General purpose I/O 13
22	VOUT	Path detect of load switch
23	VOUTG	Gate driver of load switch
24	VIN	Positive power supply
25	EPAD	Connect to ground

7. Absolute Maximum Ratings

Parameters	Symbol	Value	Unit
VIN Input Voltage Range	VIN	-0.3 ~ 45	V
VOUT Input Voltage Range	VOUT	-0.3 ~ 45	V
VOUTG Input Voltage Range	VOUTG	-0.3 ~ 45	V
DP, DM Input Voltage Range	V _{DP} , V _{DM}	-0.3 ~ 33	V
CC1, CC2 Input Voltage Range	V _{CC1} , V _{CC2}	-0.3 ~ 33	V
FB Input Voltage Range	V _{FB}	-0.3 ~ 45	V
Other Pins Input Voltage Range		-0.3 ~ 6	V
Junction Temperature Range	T _J	-40 ~ 150	°C
Storage Temperature Range	T _{stg}	-60 ~ 150	°C
Lead Temperature Range (Soldering, 10sec)	T _s	260	°C
Ambient Temperature	T _A	-40~120	°C
Package Thermal Resistance	θ _{JA}	90	°C/W
Package Thermal Resistance	θ _{JC}	39	°C/W
DP, DM, CC1, CC2 Human Body Model (HBM)	ESD	6	KV
Other Pins Human Body Model (HBM)	ESD	2	KV
Moisture Sensitivity Level (MSL)	MSL	3	Level

* Stresses beyond those listed under Absolute Maximum Ratings may cause permanent damage to the device.

Exposure to Absolute Maximum Rated conditions for extended periods may affect device reliability.

* Voltages are referenced to GND unless otherwise noted.

8. Recommended Operating Conditions

Parameter	Symbol	Min	Typ	Max	Unit
Input Voltage	VIN	3		40	V
Ambient Temperature	T _A	-20		115	°C

Devices' performance cannot be guaranteed when working beyond those Recommended Operating Conditions.

9. Electrical Characteristics

Unless otherwise specified, T A =25 °C

Parameter	Symbol	Test Conditions	Min.	Typ.	Max	Unit
Input Voltage	VIN	Supplied directly	3		40	V
Input UVLO Threshold	UVLO	VIN Falling	2.5		2.9	V
VCC	VCC			3.2		V
TYPE-C						
Rp_default	Default USB			80		μA
Rp_1.5A	1.5 A @ 5 V			180		μA
Rp_3.0A	3.0 A @ 5 V			330		μA
HVDCP (QC2.0&QC3.0&QC3+)						
Data Detect Voltage Threshold	V _{DATA_REF}		0.25	0.325	0.4	V
DP High Glitch Filter Time	T _{GLITCH(BC)_DP_H}		1000	1250	1500	ms
DM Low Glitch Filter Time	T _{GLITCH(BC)_DM_L}			2		ms
Output Voltage Glitch Filter Time	T _{GLITCH(V)_CHANGE}		20	40	60	ms
Continuous Mode Glitch Filter Time	T _{GLITCH_CONT_CHANGE}		100		200	us
DM Pull-down Resistance	R _{DM_DOWN}	VDP=0.6V		20		kOhm
DP Pull-down Resistance	R _{DAT_LKG}	VDP=0.6V		768(+ 300 configurable)		kOhm
GPIO						
VIH	Input high voltage		0.7VCC			V
VIL	Input low voltage				0.3VCC	V
VOH	Output high voltage			VCC		V
VOL	Output low voltage			GND		V
I2C						
F _{I2C}	Bit rate		100		400	KHz

10. Package

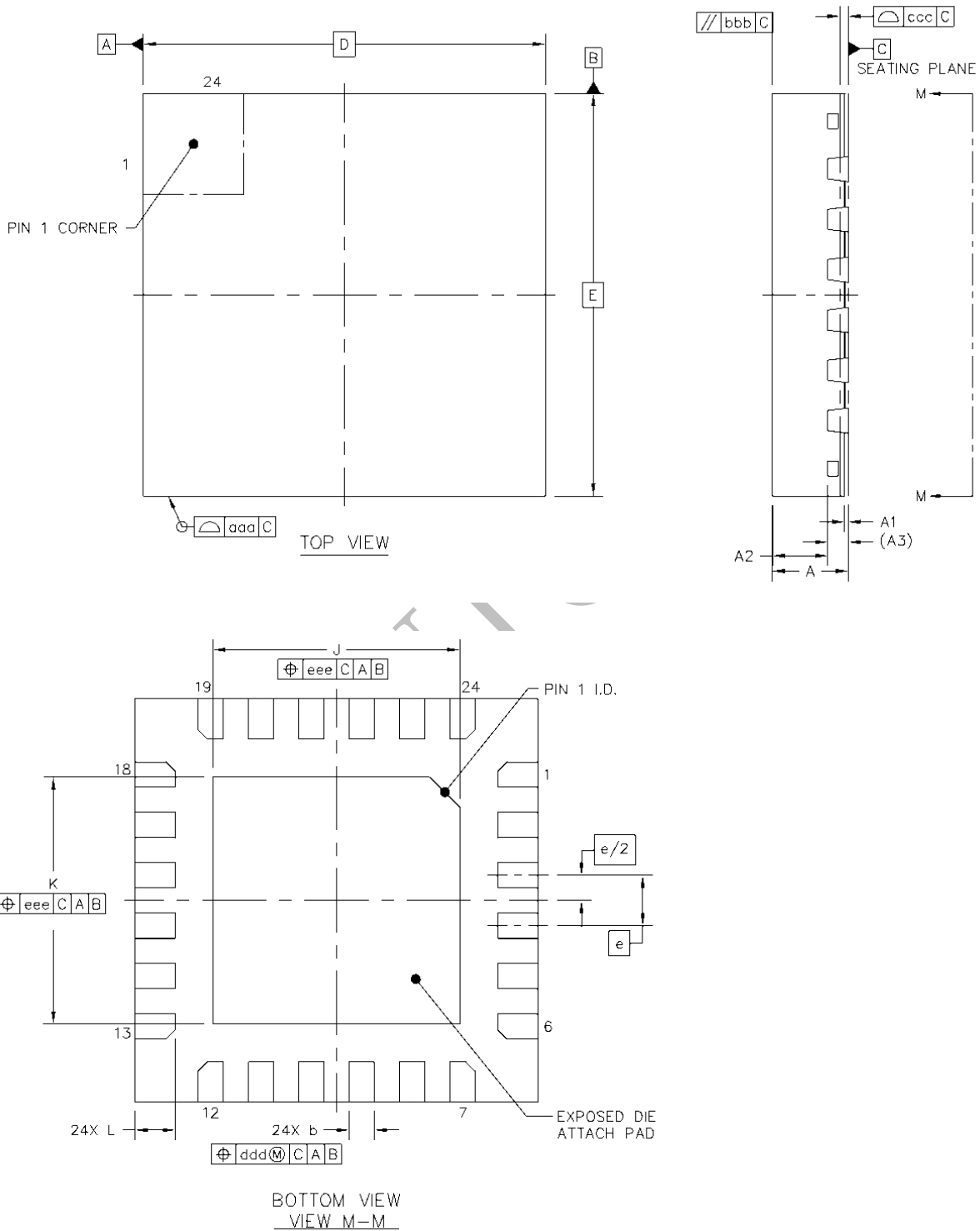

		SYMBOL	MIN	NOM	MAX
TOTAL THICKNESS		A	0.7	0.75	0.8
STAND OFF		A1	0	0.035	0.05
MOLD THICKNESS		A2	---	0.55	---
L/F THICKNESS		A3	0.203 REF		
LEAD WIDTH		b	0.2	0.25	0.3
BODY SIZE	X	D	4 BSC		
	Y	E	4 BSC		
LEAD PITCH		e	0.5 BSC		
EP SIZE	X	J	2.35	2.45	2.55
	Y	K	2.35	2.45	2.55
LEAD LENGTH		L	0.35	0.4	0.45
PACKAGE EDGE TOLERANCE		aaa	0.1		
MOLD FLATNESS		bbb	0.1		
COPLANARITY		ccc	0.08		
LEAD OFFSET		ddd	0.1		
EXPOSED PAD OFFSET		eee	0.1		

INJOINIC

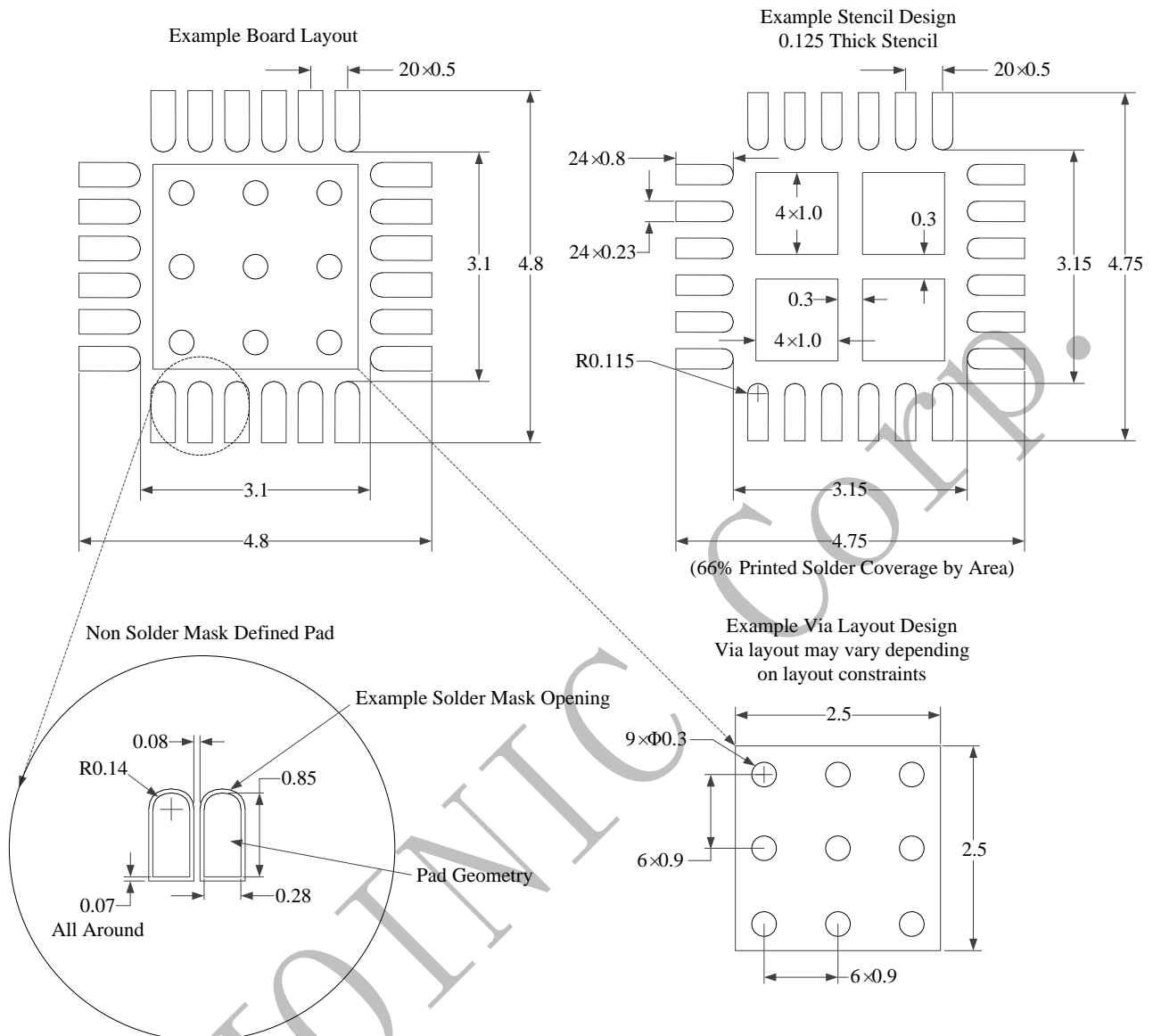

- NOTES: 1. All linear dimensions are in millimeters.
2. This drawing is subject to change without notice.
3. Customers should contact their board fabrication site for recommended solder mask tolerances and via tenting recommendations for vias placed in the thermal pad.

11. Tape and Reel Information

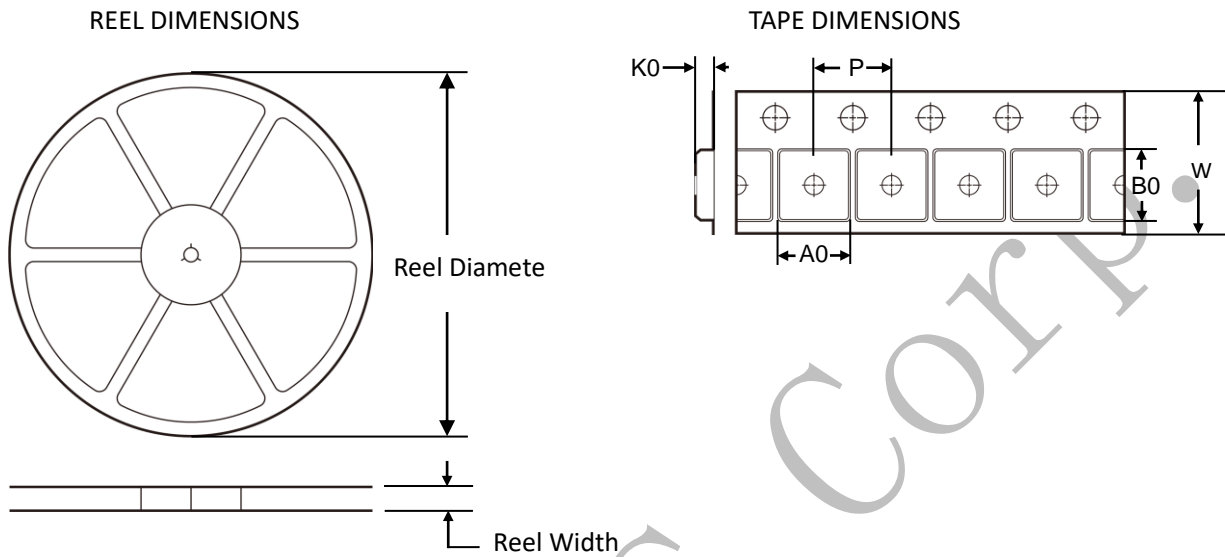

QUADRANT ASSIGNMENTS FOR PIN 1 ORIENTATION IN TAPE IS Q1

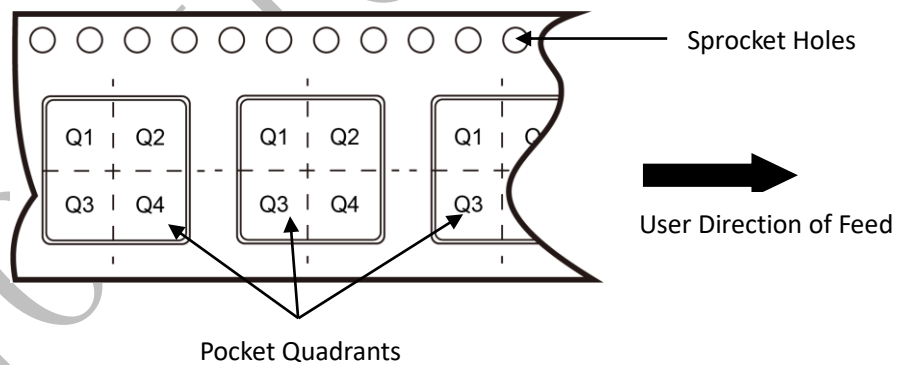

*所有尺寸为标准尺寸

Device	Package Type	Pins	SPQ	Reel Diameter (mm)	Reel Width (mm)	A0 (mm)	B0 (mm)	K0 (mm)	P (mm)	W (mm)	Pin1 Quadrant
IP2756	QFN24	24	5000	330	12.5	4.45 ± 0.10	4.50 ± 0.10	1.20 ± 0.10	8.0 ±0.1	12 ±0.3	Q1

TAPE AND REEL BOX DIMENSIONS

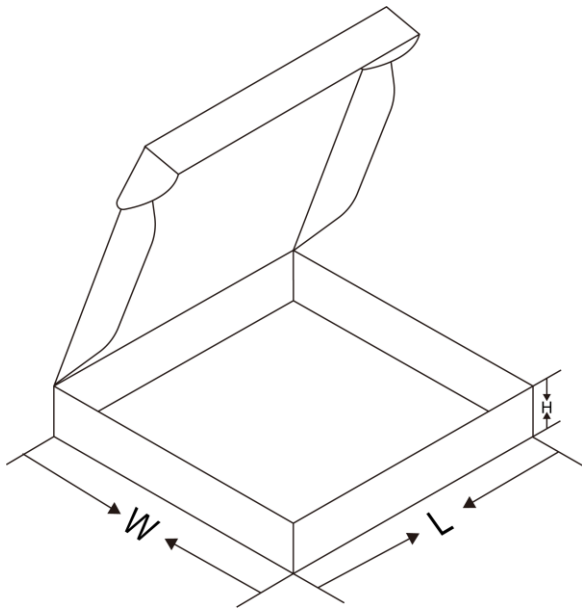

*All dimensions are nominal

Package Type	PCS /Tape Reel	Tape Reel /Inner box	PCS /Inner box	Inner box /Carton	PCS /Carton	W (mm)	L (mm)	H (mm)
QFN24	5000	2	10000	6	60000	360	360	50





外箱尺寸:385*345*380mm

内盒尺寸:360*360*50mm

12. Marking Specification



说明:

- 1、  ——英集芯标志
- 2、 IP2756 ——产品型号
- 3、 XXXXXXXX ——生产批号
- 4、  ——Pin 1脚位置标识

13. Picture of Material Object

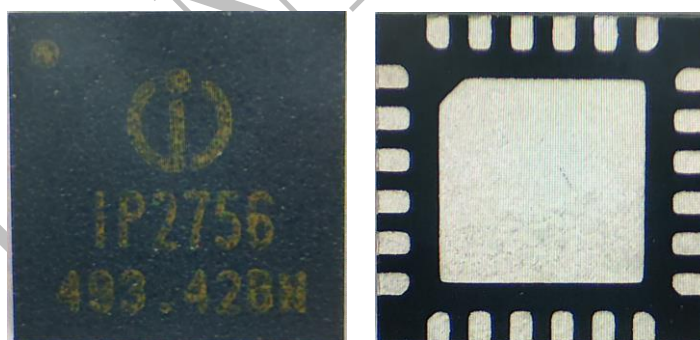

14. Solder Instruction

温度设置 (摄氏度)							
温区	1	2	3	4	5	6	7
上温区	130	140	160	160	200	320	265
下温区	130	140	160	160	200	320	265
传送带速度 (公分/分):	39.0						

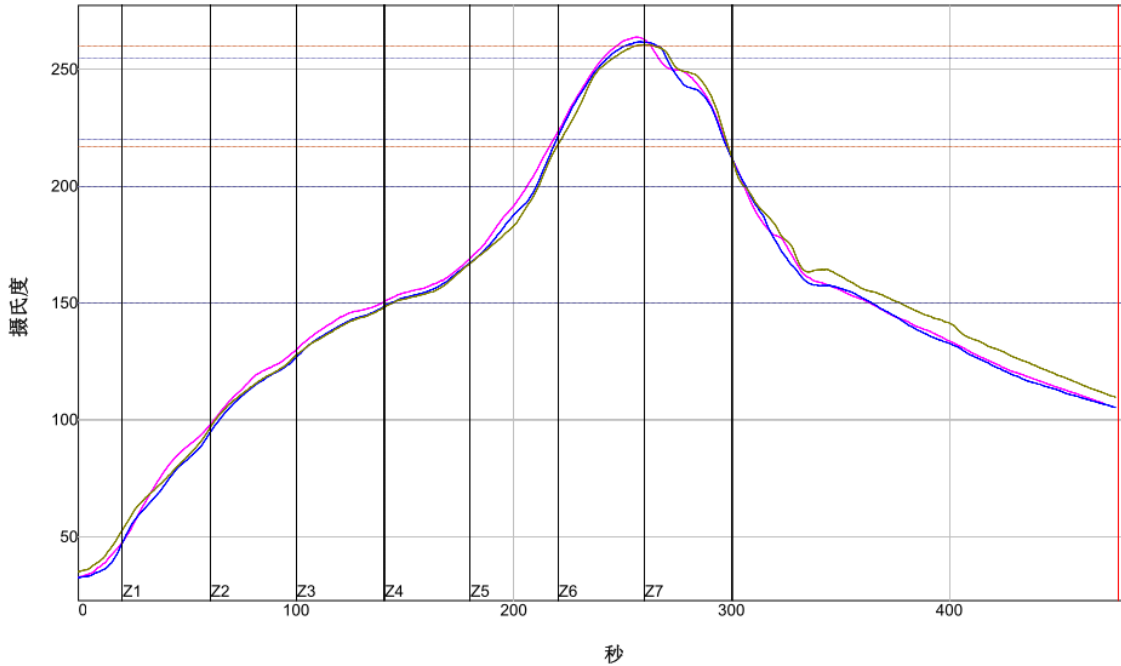

PWI=75%	最高上升斜率	预热150至200C		最高温度		总共时间 /217C		斜率1 (217-260C)		预热220至255C-(2)		总共时间 /260C-2		距峰值5C区域时间		
VP 1	1.69	-31%	66.21	-59%	263.87	18%	80.99	-70%	1.70	-30%	22.81	-36%	15.90	-30%	18.13	-75%
VP 2	1.99	-1%	66.91	-54%	261.84	-9%	78.97	-73%	1.87	-13%	23.44	-33%	15.74	-31%	23.64	-31%
VP 3	1.83	-17%	66.61	-56%	260.76	-23%	78.19	-74%	1.88	-12%	23.97	-30%	9.37	-66%	23.95	-28%
温差	0.30		0.70		3.11		2.80		0.18		1.16		6.53		5.82	

制程界限:

统计数名称	最低界限	最高界限	单位
锡膏: 260			
最高温度上升斜率 (目标=2.0) (计算斜率的时间距离= 20 秒)	1.0	3.0	度/秒
斜率1 (目标=2.0) 介于 217.0 和 260.0 (计算斜率的时间距离= 10 秒)	1.0	3.0	度/秒
预热时间150-200摄氏度	60	90	秒
预热时间220-255摄氏度-(2)	10	50	秒
最高温度	255	270	度 摄氏度
在217摄氏度以上时间	60	200	秒
在260摄氏度以上时间-(2)	3	40	秒
距峰值5C区域时间	15	40	秒

15. IMPORTANT NOTICE

INJOINIC TECHNOLOGY and its subsidiaries reserve the right to make corrections, enhancements, improvements and other changes to its semiconductor products and services. Buyers should obtain the latest relevant information before placing orders and should verify that such information is current and complete. All semiconductor products (also referred to herein as “components”) are sold subject to INJOINIC TECHNOLOGY's terms and conditions of sale supplied at the time of order acknowledgment.

INJOINIC TECHNOLOGY assumes no liability for applications assistance or the design of Buyers' products. Buyers are responsible for their products and applications using INJOINIC TECHNOLOGY's components. To minimize the risks associated with Buyers' products and applications, Buyers should provide adequate design and operating safeguards.

Buyer acknowledges and agrees that it is solely responsible for compliance with all legal, regulatory and safety-related requirements concerning its products, and any use of INJOINIC TECHNOLOGY's components in its applications, notwithstanding any applications-related information or support that may be provided by INJOINIC TECHNOLOGY. Buyer represents and agrees that it has all the necessary expertise to create and implement safeguards which anticipate dangerous consequences of failures, monitor failures and their consequences, lessen the likelihood of failures that might cause harm and take appropriate remedial actions. Buyer will fully indemnify INJOINIC TECHNOLOGY and its representatives against any damages arising out of the use of any INJOINIC TECHNOLOGY's components in safety-critical applications.

Reproduction of significant portions of INJOINIC TECHNOLOGY's information in INJOINIC TECHNOLOGY's data books or data sheets is permissible only if reproduction is without alteration and is accompanied by all associated warranties, conditions, limitations, and notices. INJOINIC TECHNOLOGY is not responsible or liable for such altered documentation. Information of third parties may be subject to additional restrictions.

INJOINIC TECHNOLOGY will update this document from time to time. The actual parameters of the product may vary due to different models or other items. This document voids all express and any implied warranties.

Resale of INJOINIC TECHNOLOGY's components or services with statements different from or beyond the parameters stated by INJOINIC TECHNOLOGY for that component or service voids all express and any implied warranties for the associated INJOINIC TECHNOLOGY's component or service and is an unfair and deceptive business practice. INJOINIC TECHNOLOGY is not responsible or liable for any such statements.