

TWS Bluetooth Earphone Charging Box SOC integrated TYPE-C Protocol with 1A charger and discharger

1 Features

- **Switch buck charger and boost**
 - ◇ 1A synchronous switching charger and 5V 1A boost converter
 - ◇ Boost converter efficiency up to 92%
 - ◇ Switch charger efficiency up to 91%
- **Charge**
 - ◇ Automatically adjusts charging current to adapt to different load capacity adapters
 - ◇ Supports 4.20V, 4.30V 4.35V, 4.40V batteries
- **Battery indicators**
 - ◇ Built-in 12bits ADC
 - ◇ Supports 4/3/2/1 LED battery indicator
 - ◇ 188 series models support Coulometer
- **Fully featured**
 - ◇ Supports NTC function
 - ◇ Supports selecting battery initial capacity by external PIN
 - ◇ Supports selecting charging current by external PIN
 - ◇ Supports detection of earphone plug-in/plug-out independently
 - ◇ Supports detection of TYPE-C plug-in/plug-out automatically
 - ◇ Integrated TYPE-C DRP protocol, Support for charging and discharging in the one TYPE-C port
 - ◇ Double UART, support earphone independent communication function
- **Low power**
 - ◇ Automatically detect load plugged-out, Automatically enter standby mode
 - ◇ Standby power consumption up to 20uA minimum
- **Simplified BOM**
 - ◇ Built-in power MOS, charging and boosting with a 1uH single inductor
- **Multiple protection, high reliability**
 - ◇ Output: over current and short circuit protection
 - ◇ Independent binaural current limiting protection
 - ◇ Input: under voltage protection, over voltage protection and Battery over charged

protection

- ◇ Over temperature protection
- ◇ VBUS pin can withstand up to 15V(transient voltage)

- **In-depth customization**

- ◇ Flexible and low-cost customized program

- **Package:QFN24 4mm*4mm**

2 Applications

- TWS Bluetooth Earphone Charging Box
- Emergency Power Bank

3 Description

IP5333 is a multi-functional power management SOC that integrates boost converter, lithium battery charge management, battery level indicator and Type-C protocol for total solution on TWS Bluetooth Earphone Charging BOX.

IP5333 is highly integrated with abundant functions, which makes the total solution with minimized-size and low-cost BOM.

IP5333 only requires one inductor to realize buck and boost functions. Supports low-cost inductors and capacitors.

The synchronous boost system of IP5333 provides rated 1A output current with conversion efficiency up to 92%. Under light load, the charging BOX automatically enters sleep state, and the standby current can be reduced to 20uA.

IP5333 adopts switch charging technology to provide rated 1A charging current with switching efficiency up to 91%. Built-in IC temperature protection and input voltage intelligent adjustment of charging current.

IP5333 can support 1/2/3/4 LED battery indicator and the built-in 12bits ADC can accurately calculate the Charging Box's battery voltage and current.

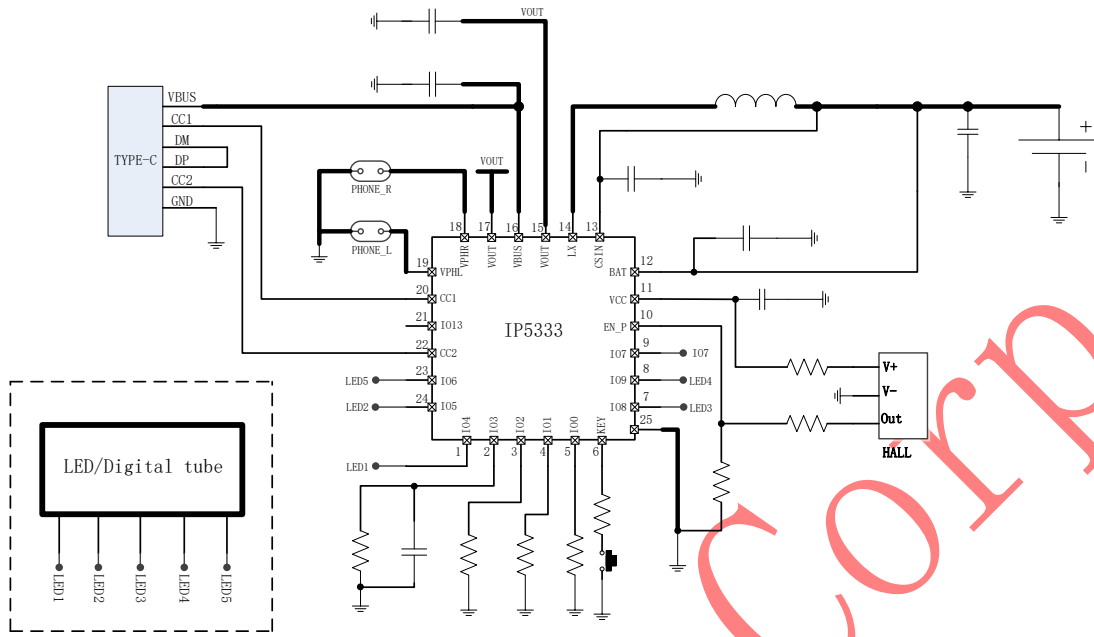

Figure1 IP5333 Simplified Application Diagram

4 Pin Definition

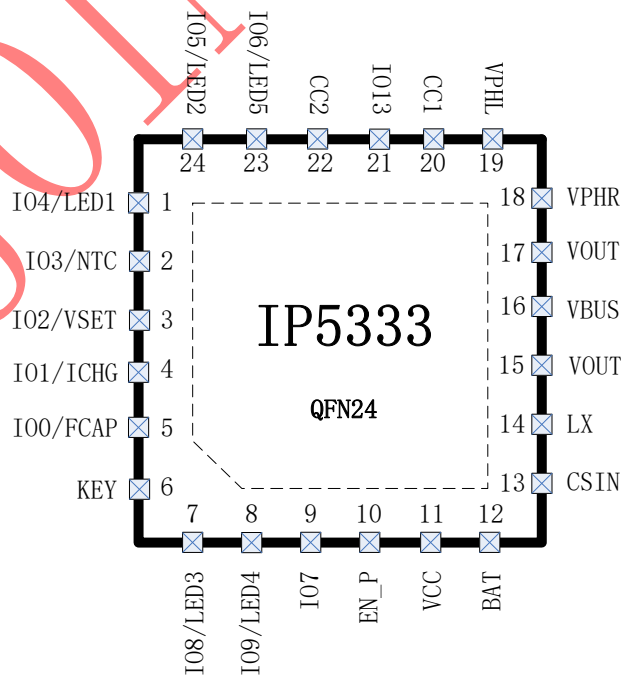

Figure2 IP5333 Pin Assignments

Pin		Description
Pin Num	Name	
1	IO4/LED1	IO4/ LED driver pin1
2	IO3/NTC	IO3/NTC function pin
3	IO2/VSET	IO2/Full battery voltage setting pin
4	IO1/ICHG	IO1/Charging current setting pin
5	IO0/FCAP	IO0/Battery capacity setting pin
6	KEY	KEY driver pin
7	IO8/LED3	IO8/LED driver pin3
8	IO9/LED4	IO9/LED driver pin4
9	IO7	IO7
10	EN_P	Hall switch output signal, default drop-down
11	VCC	LDO 3.1V output pin
12	BAT	Battery voltage positive pin
13	CSIN	Bat voltage sampling pin
14	LX	DCDC switch node
15	VOUT	Boost 5v output
16	VBUS	USB Type-c power pin
17	VOUT	Boost 5v output
18	VPHR	Right earphone positive pin
19	VPHL	Left earphone positive pin
20	CC1	USB Type-C CC1 pin
21	IO13	IO13
22	CC2	USB Type-C CC2 pin
23	IO6/LED5	IO6/ LED driver pin5
24	IO5/LED2	IO5/ LED driver pin2
25	EPAD/PGND	Ground

5 IP Series TWS Charging IC Products List

IC Part No.	Charge-discharge		Main features							
	discharge	charge	Wireless charging	LED	KEY	HALL	VSET	NTC	USB C	Package
IP5513	300mA	IO option	-	1/2/3/4/ Digital Tube	Support		Customizable	Customizable	-	SOP16
IP5516	300mA	IO option	-	1/2/3/4/ Digital Tube	Support	Support	Customizable	Support	-	QFN16
IP5518	300mA	IO option	-	1/2/3/4/ Digital Tube	Support	Support	Customizable	Support	-	QFN24
IP6816	300mA	Customizable	Support	1/2/3/4/ Digital Tube	Support	Support	Customizable	Support	-	QFN16
IP6818	300mA	Customizable	Support	1/2/3/4/ Digital Tube	Support	Support	Customizable	Support	-	QFN24
IP5333	1A	IO option	-	1/2/3/4/ Digital Tube	Support	Support	IO option	Support	Support	QFN24
IP5416	200mA	500mA	-	1/2	Support	Support	Customizable	-	-	SOP8
IP5413T	200mA	500mA	-	1/2/4	Support	-	Customizable	-	-	SOP8

Not supported:-

6 IP5333 IC Products List

IC Part No.	LED	Battery capacity setting	Coulometer	Circuit difference
IP5333_BZ_LED	1/2/3/4	-	-	No 10mR sampling resistance
IP5333_BZ_188	Digital Tube	GPIO0	Support	A 10mR sampling resistance

Not supported:-

7 Absolute Maximum Ratings

Parameter	Symbol	Value	Unit
VBUS Input Voltage Range	Vbus_in	-0.3 ~ 12	V
Junction Temperature Range	T _J	-40 ~ 150	°C
Storage Temperature Range	T _{stg}	-60 ~ 150	°C
Thermal Resistance (Junction to Ambient)	θ _{JA}	40	°C/W
ESD (Human Body Model)	ESD	4	KV

*Stresses beyond these listed parameter may cause permanent damage to the device.

Exposure to Absolute Maximum Rated conditions for extended periods may affect device reliability.

8 Recommended Operating Conditions

Parameter	Symbol	Min.	Typ.	Max.	Unit
Input voltage	Vbus_in	4.5	5	5.8	V
Operating Temperature	T _A	-10	--	85	°C

*Device performance cannot be guaranteed when working beyond these Recommended Operating Conditions.

9 Electrical Characteristics

Unless otherwise specified, TA=25°C, L=1uH

Parameter	Symbol	Test conditions	Min.	Typ.	Max.	Unit
Charging System						
Input Voltage	Vbus_in	VBAT=3.7V	4.6	5	5.8	V
Input Over Voltage	Vbus_inOV		5.8	6.0	6.2	V
Input Under Voltage	Vbus_inUV	Vout voltage	4.55	4.60	4.65	V
Constant Charge Voltage	CV4.2V	4.2V battery configuration	4.18	4.21	4.24	V
	CV4.30V	4.3V battery configuration	4.28	4.31	4.34	V
	CV4.35V	4.35V battery configuration	4.33	4.36	4.4	V
	CV4.4V	4.4V battery configuration	4.38	4.41	4.44	V
Charge Stop Current	Ivbus_instop	Vbus_in=5V		100	200	mA
Charge Current	Ivbus_in	Vbus=5V, VBAT=3.7V, Riset=NC VBUS port charge current		1	1.2	A
Trickle Charge Current	ITRKL	Vbus_in=5v, BAT=2.7v	70	100	120	mA
Trickle Charge Stop Voltage	VTRKL		2.9	3	3.1	V
Recharge Voltage Threshold	VRCH		4.04	4.07	4.10	V
Boost System						
Battery Operation Voltage	V _{BAT}		3	3.7	4.4	V
Low Power Shutdown Voltage	V _{BATLOW}	IOUT=1A	2.9	3.0	3.05	V
DC Output Voltage	V _{bus}	VBAT=3.7V @0A	5.0	5.12	5.25	V
		VBAT=3.7V @1A	4.75	5.0	5.15	V
Output Voltage Ripple	ΔV _{OUT}	VBAT=3.0V~4.4V @Iout=1A	50	100	150	mV
Boost Output Current	I _{vout}	VBAT=3.7V	0	1		A

Boost Overcurrent Shut Down Threshold	$I_{shut-vbus}$	VBAT=3.7V		1.3		A
Earphone Overcurrent Shut Down Threshold	$I_{shut-vph}$	VBAT=3.7V		250	300	mA
Load Overcurrent Detect Time	T_{UVD}	Duration of output voltage under 4.4V		30		ms
Control System						
Switch Frequency	f_s	Discharge switch frequency		1000		KHz
		Charge switch frequency		1000		KHz
PMOS On Resistance	r_{DSON}			110		mΩ
NMOS On Resistance				95		mΩ
VBUS OVP On Resistance	R_{ovp}			120		mΩ
VCC Voltage	VCC	Vbat=3.7V		3.1		V
Battery Input Standby Current	I_{STB}	Vbus_in=0V, VBAT=3.7V		20	25	uA
IO Driving Current	I_{Gpio}			5		mA
Light Load Shut Down Detect Time	T_{loadD}	Load current less than 100mA	8	10	12	s
Light Load Shut Down Current	$I_{plout-vbus}$	VBAT=3.7V, TYPE-C, No 10mR resistance		120		mA
		VBAT=3.7V, TYPE-C, 10mR resistance		40		mA
	$I_{plout-ph}$	VBAT=3.7V, VPH pin		4		mA
Short Press On Key Wake Up Time	$T_{OnDebounce}$		60		300	ms
Thermal Shut Down Temperature	T_{OTP}	Rising temperature	130	140	150	°C
Thermal Shut Down Hysteresis	ΔT_{OTP}		30	40	50	°C

10 IC Mark Description

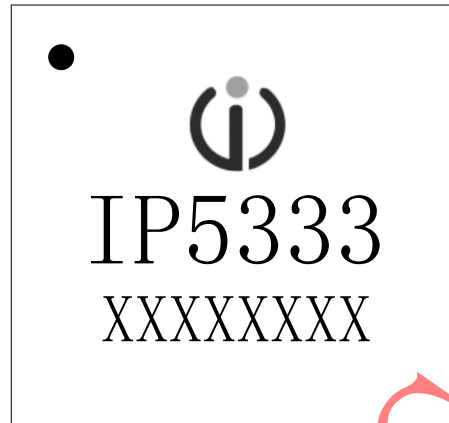

Note:

- 1、  --Injoinic Logo
- 2、 IP5333 --Part Number
- 3、 XXXXXXXX --Manufacture number
- 4、 ● --PIN 1 location

Figure3 IP5333 Mark Description

11 Function Description

System Diagram

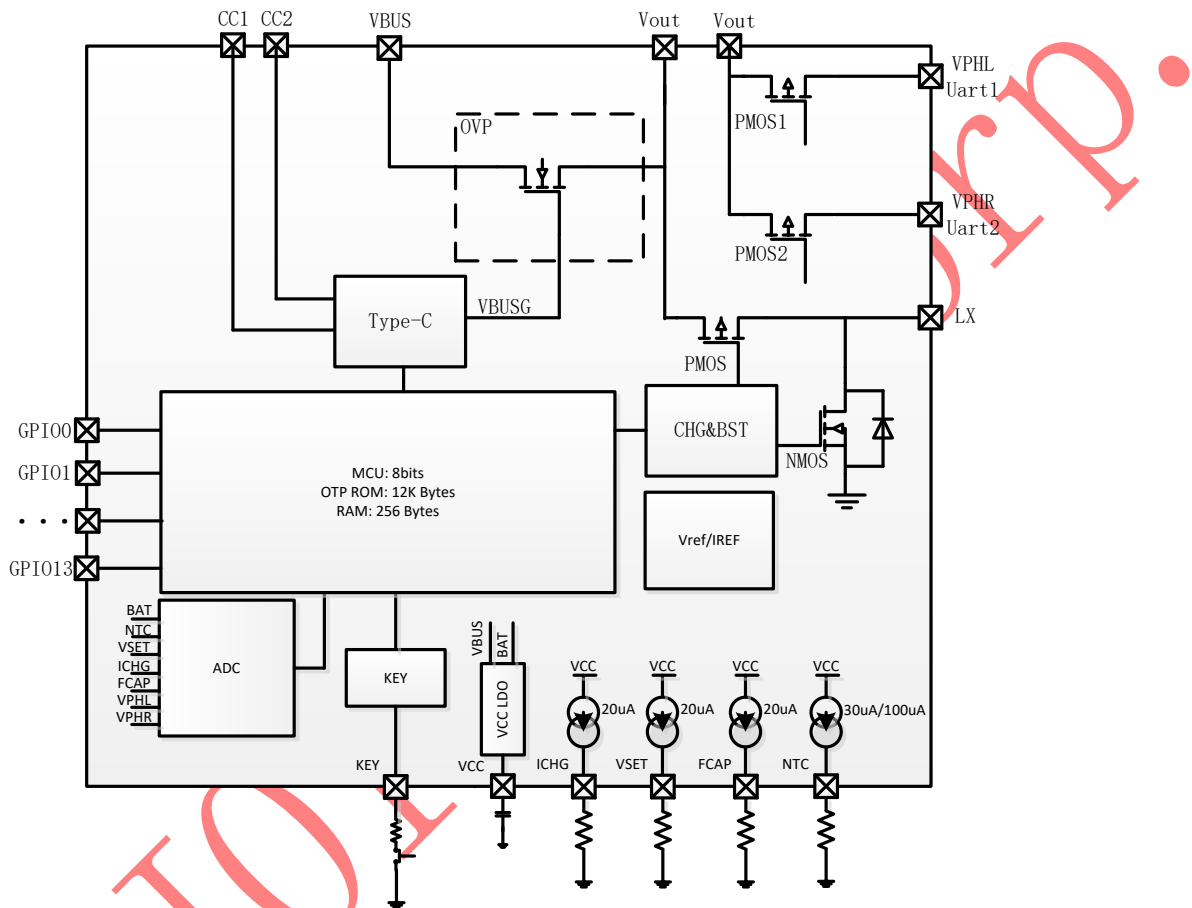

Figure4 IP5333 Internal System Diagram

Boost

IP5333 integrates a boost dc-dc converter with 5V1A output. Switching frequency: 1MHz; input: 3.7V; efficiency @ 5V/1A output: 92%. It is to prevent the rush current at the start with built-in soft start function. And it is to ensure the system stable and reliable with integrated output over current, short circuit, over voltage, over temperature and other protection. The output current of the boost system can be automatically adjusted with the temperature to ensure that the IC is below the setted temperature.

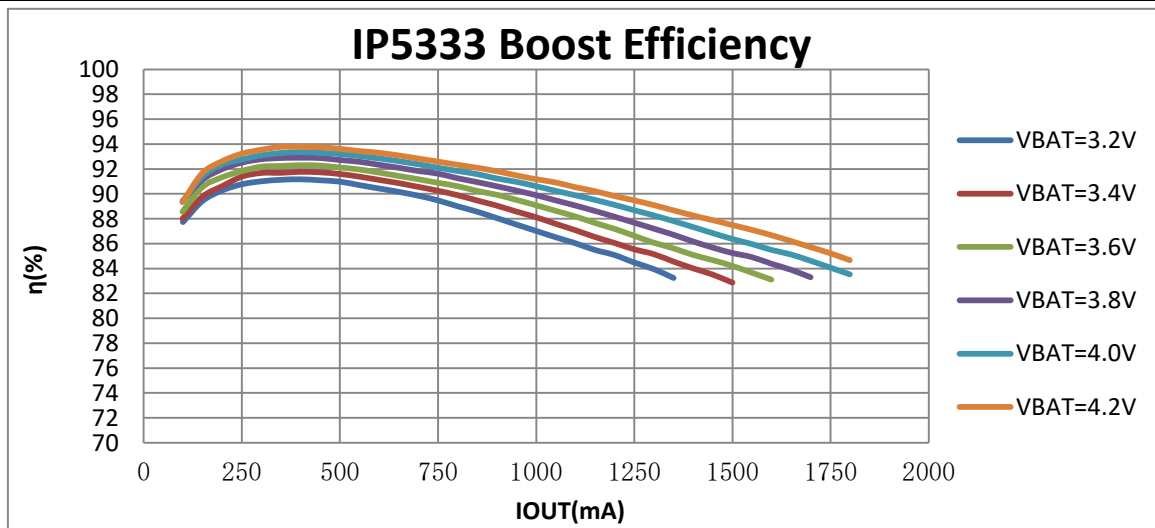

Figure5 IP5333 Boost Efficiency Curve

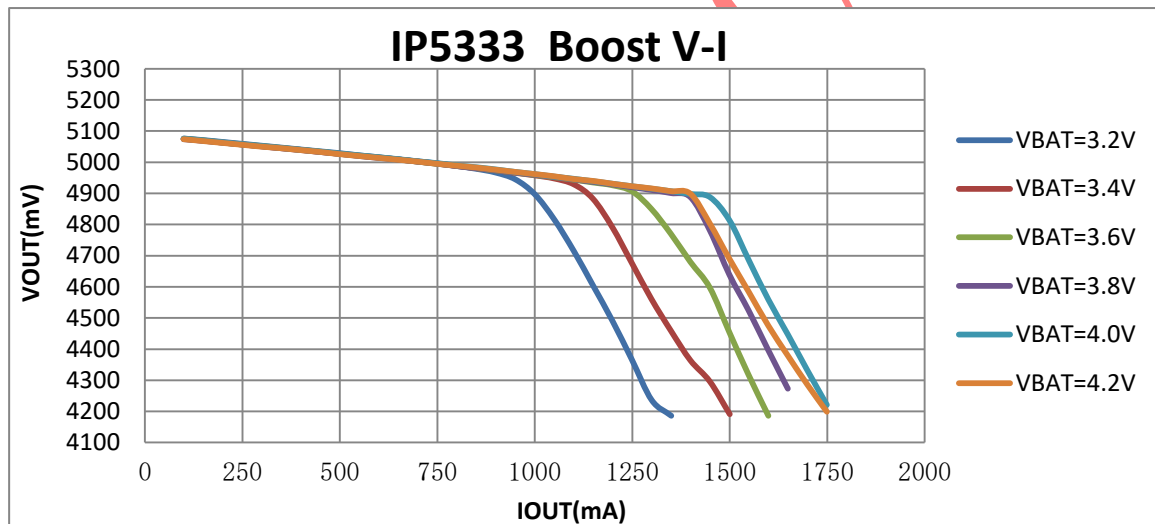

Figure6 IP5333 Boost Output V-I Curve

Charge

IP5333 integrates a constant-current and constant-voltage Li battery charging management system with synchronous switch. When the battery voltage is lower than 3V, Charge Box enters precharge state with 100mA; when the battery voltage is higher than 3V, enters constant current CC charging stage; when the battery voltage is close to the preset battery voltage, enters constant voltage charging stage. When the charging is accomplished, once the battery voltage falls under 4.1V, battery charging will be restarted.

IP5333 supports TYPEC port 1A charging, and at the same time detects the input voltage and IC temperature to automatically adjust the charging current.

When IP5333 is in charging state, it will detect whether the V_{OUT} (output voltage) is higher than 4.6V. If it is higher than 4.6V, it will charge the battery with the maximum current; if it is lower than 4.6V, it will reduce the charging current and automatically adapt to the load output capacity of the adapter.

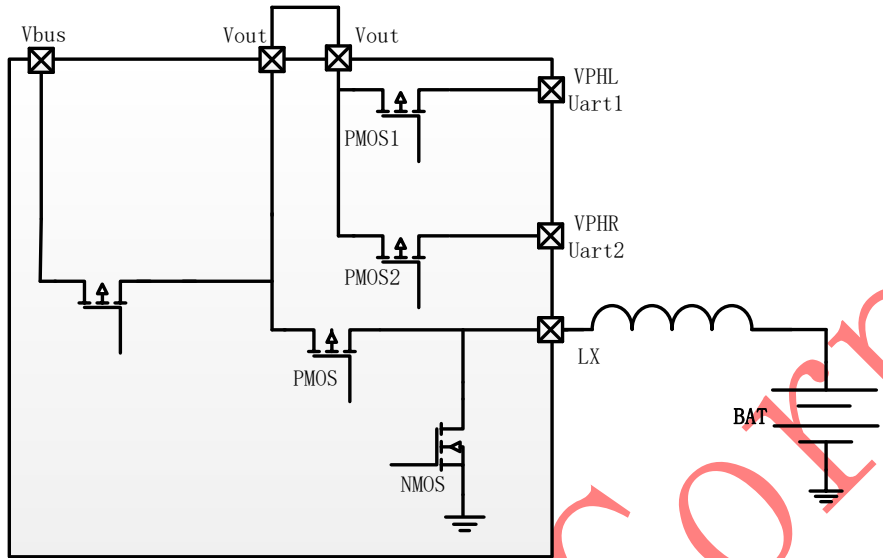

Figure7 Schematic Diagram Of Power Path Management

USB C

IP5333 integrated USB C DRP port, auto-switching the internal pull-up and pull-down circuit on CC1 and CC2 by distinguishing the role of the attached device. Support Try.SRC function, when the attached device is also DRP device, IP5333 will supply power for the opposite device.

When worked as DFP, the output current can be set as default levels; when worked as UFP, the current capability from the opposite device can be detected.

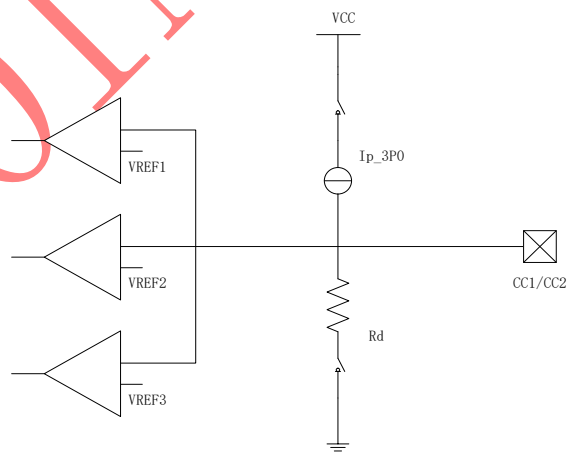

Figure8 CC Internal Circuit

Pull-up and pull-down ability:

Name	Value
Ip_3P0	80uA
Rd	5.1K

Comparator Threshold of pull-up Ip:

	Minimum Voltage	Maximum Voltage	Threshold
Powered cable/adaptor (vRa)	0.00 V	0.15 V	0.20 V
Sink (vRd)	0.25 V	1.50 V	1.60 V
No connect (vOPEN)	1.65 V		

Comparator Threshold of Pull-down Resistor Rd:

Table 4-25 Voltage on Sink CC pins (Multiple Source Current Advertisements)

Detection	Min voltage	Max voltage	Threshold
vRa	-0.25 V	0.15 V	0.2 V
vRd-Connect	0.25 V	2.04 V	
vRd-USB	0.25 V	0.61 V	0.66 V
vRd-1.5	0.70 V	1.16 V	1.23 V
vRd-3.0	1.31 V	2.04 V	

USB C detects cycle:

Figure 4-36 DRP Timing

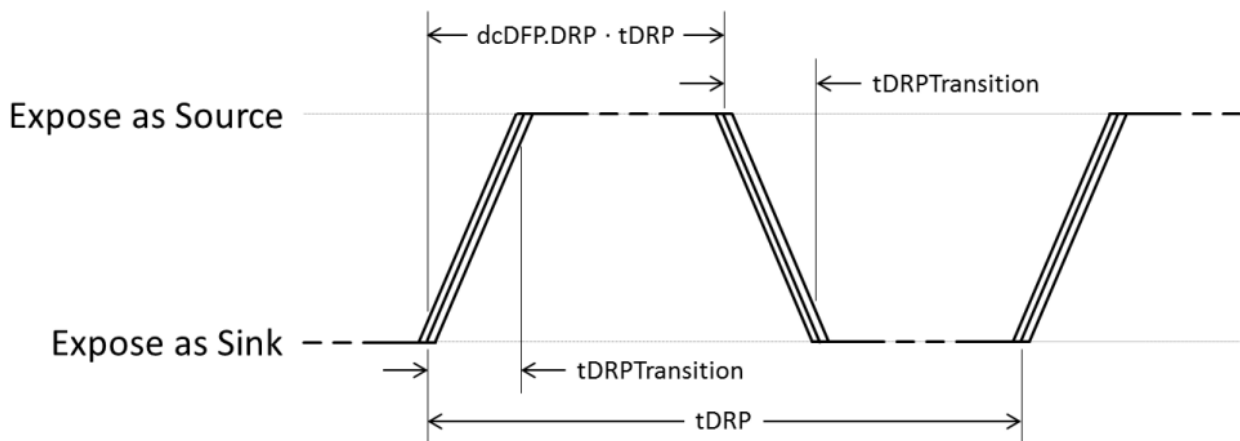
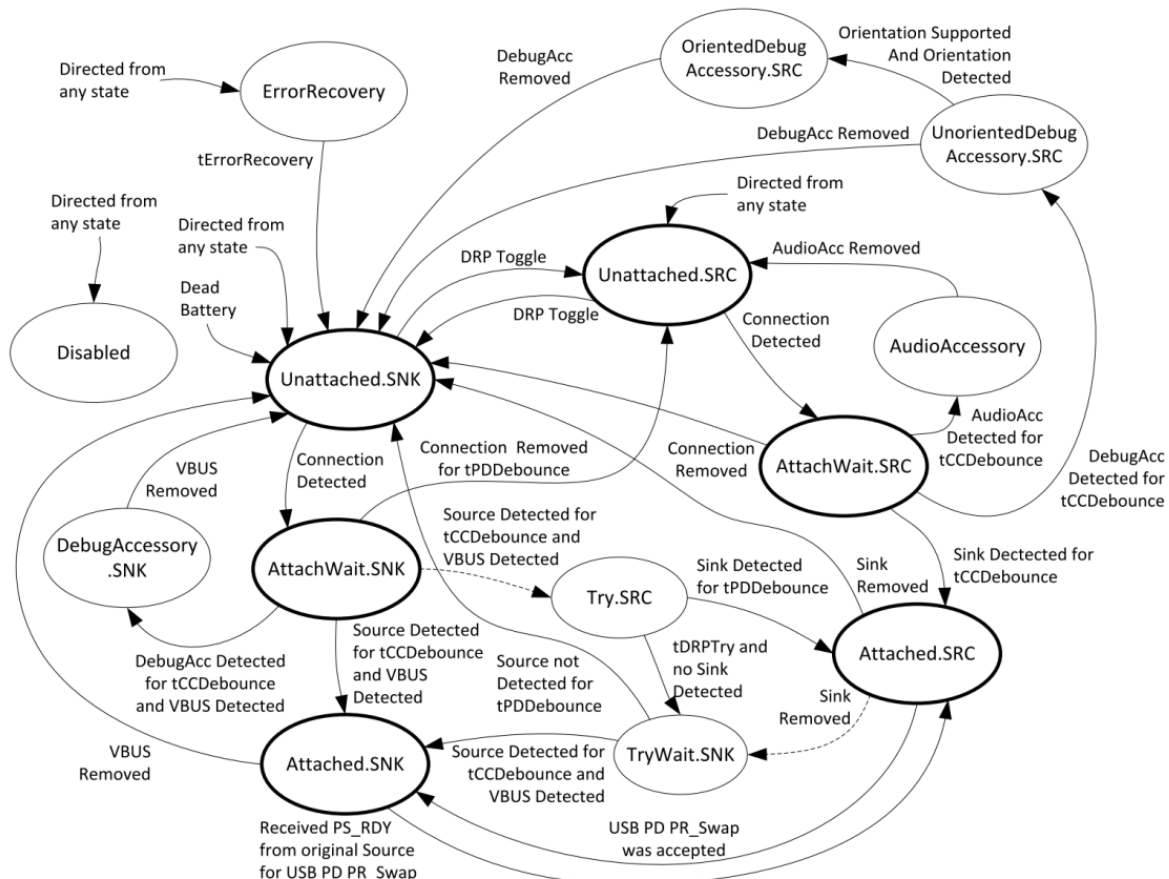

Table 4-21 DRP Timing Parameters

	Minimum	Maximum	Description
tDRP	50 ms	100 ms	The period a DRP shall complete a Source to Sink and back advertisement
dcSRC.DRP	30%	70%	The percent of time that a DRP shall advertise Source during tDRP
tDRPTransition	0 ms	1 ms	The time a DRP shall complete transitions between Source and Sink roles during role resolution
tDRPTry	75 ms	150 ms	Wait time associated with the Try.SRC state.
tDRPTryWait	400 ms	800 ms	Wait time associated with the Try.SNK state.

USB C detects state transition:

Figure 4-16 Connection State Diagram: DRP with Accessory and Try.SRC Support



Key

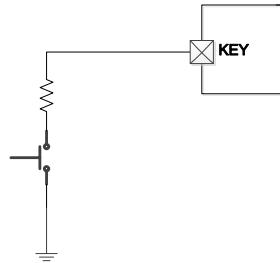

Figure9 Key Circuit

- Pressed time in range of 100ms ~ 2s, turn on the battery indicator and boost output.
- Two short press in 1s, turn off boost output and battery indicator.

Coulombmeter and battery level display

IP5333 has a built-in power algorithm, which can accurately display the remaining battery power according to the cell capacity.

IP5518 can support 1/2/3/4 LED battery indicator, and the system can automatically identify several LED modes.

IP5518 can also support other power displays such as breathing lights and 188 digital tubes. Such special lights need to be customized separately. Please contact INJOINIC technical support department.

LED display mode

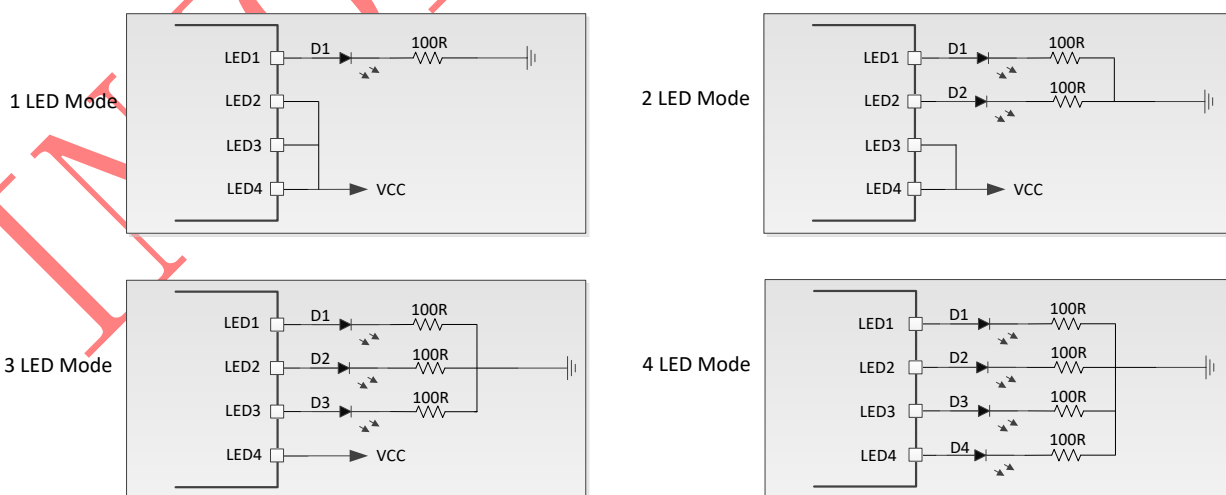

Figure10 LED Display Mode Configuration Circuit

■ 4 LED Mode

Discharge

Battery capacity(c)(%)	D1	D2	D3	D4
$C \geq 75\%$	on	on	on	on
$50\% \leq C < 75\%$	on	on	on	off
$25\% \leq C < 50\%$	on	on	off	off
$3\% \leq C < 25\%$	on	off	off	off
$0\% < C < 3\%$	1Hz blink	off	off	off

Charge

Battery capacity(c)(%)	D1	D2	D3	D4
full	on	on	on	on
$75\% \leq C$	on	on	on	0.5Hz blink
$50\% \leq C < 75\%$	on	on	0.5Hz blink	off
$25\% \leq C < 50\%$	on	0.5Hz blink	off	off
$C < 25\%$	0.5Hz blink	off	off	off

■ 3 LED Mode

Discharge

Battery capacity(c)(%)	D1	D2	D3
$C \geq 66\%$	on	on	on
$33\% \leq C < 66\%$	on	on	off
$3\% \leq C < 33\%$	on	off	off
$0\% < C < 3\%$	1Hz blink	off	off

Charge

Battery capacity(c)(%)	D1	D2	D3
$C = 100\%$	on	on	on
$66\% \leq C < 100\%$	on	on	0.5Hz blink
$33\% \leq C < 66\%$	on	0.5Hz blink	off
$C < 33\%$	0.5Hz blink	off	off

■ 2 LED Mode

	state	D1	D2
charge	charging	0.5Hz blink	off
	full	on	off
discharge	discharging	off	on
	low	off	1Hz blink

■ 1 LED Mode

	state	D1
charge	charging	0.5Hz blink
	full	on
discharge	discharging	on
	low	1HZ blink

Digital Tube Display Mode

Digital Tube	Charge		Boost	
	In Charging	Full	C<5%	C>5%
5pin 188 mode (YF2252SR-5)	0-99% 0.5HZ blink	100% Always bright	0-5% Single digit1HZ blink	5%-100% Always bright

IP5333 supports 5PIN 188 by default. The schematic diagram is as follows:

(未注尺寸公差 Unspecified Tolerances is: ± 0.2 发光颜色: 红色)

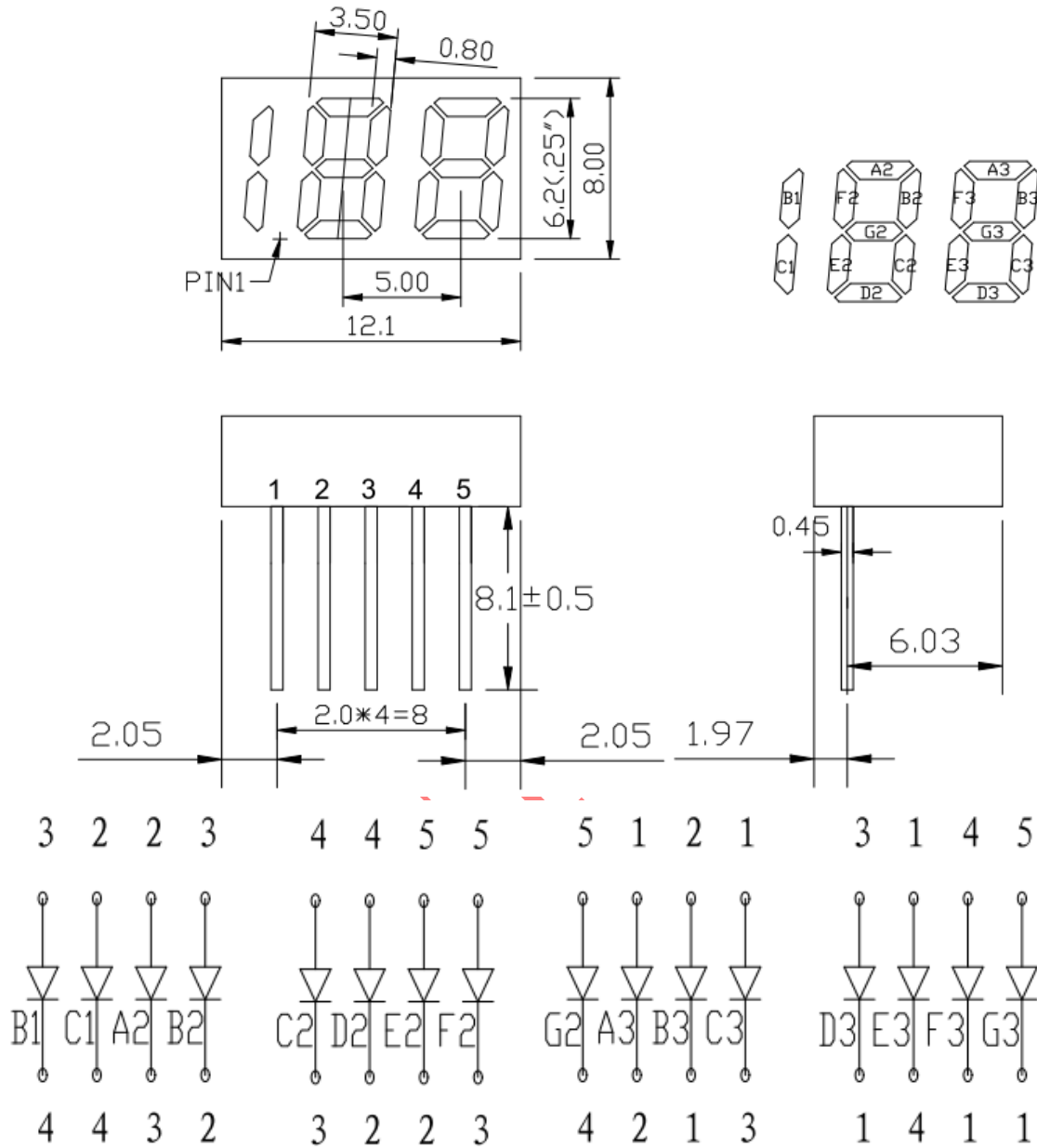

Figure 11 5pin 188 Digital Tube Circuit Diagram

	IP5333 LED Driver Pin	Digital Tube Pin	Note
Mapping relationship between IP5333 LED driver pin and digital tube pin	LED1 (1 pin)	1 pin	
	LED2 (24 pin)	2 pin	
	LED3 (7 pin)	3 pin	
	LED4 (8 pin)	4 pin	
	LED5 (23 pin)	5 pin	

Coulombmeter

IP5333_188 supports the external setting of the initial capacity of the battery. The residual capacity of the battery can be managed by integrating the current and time of the battery end, which can accurately display the current capacity of the battery.

At the same time, IP5333_188 supports a complete charging process from 0% to 100% to automatically calibrate the total capacity of the current battery, so as to manage the actual capacity of the battery more reasonably.

Plug-in/Plug-out Detection

After IP5333 detects the phone is inserted into VBUS, it will immediately wake up from standby mode and turn on the boost 5V to charge the phone.

Once detecting the insertion of the earphone, the IP5333 wakes up from the standby mode and turns on the boost 5V to charge the earphone, eliminating the button operation and supporting the buttonless mold solution. In the standby mode, the VPHL/VPHR output voltage has two configurations: 5V and 3.0V. The standard standby VPHL/VPHR output voltage is 3.0V.

When VPHL/VPHR detects a pull-down of more than 5uA, it is considered that there is load insertion.

When VPHL/VPHR detects a pull-down below 10uA, it is considered that there is load pull-out.

The IP5333 supports light-load auto standby function. When the VBUS load current is less than 120mA and the earphone load current on VPHL and VPHR is less than 4mA and lasts for 10s, it will automatically enter the standby mode.

IP5333 supports binaural independent current limiting 250ma protection: the current is limited by the NMOS on the output path, when it is detected that the current of the MOS transistor reaches about 250ma, the output path is closed.

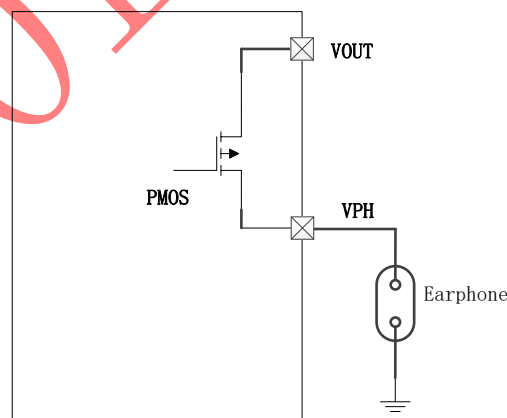

Figure12 IP5333 Earphone Connection Schematic

NTC Function

IP5333 integrates NTC function, which can detect battery temperature. When the IP5333 is working, NTC pin generates a constant current source, and generates voltage through external NTC resistance. IC internally detects the voltage of the NTC pin to determine the current battery temperature.

* The 100nF capacitance of NTC must be close to IC PIN.

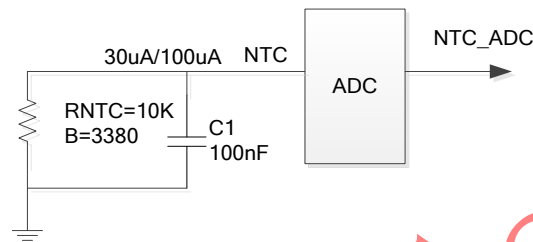

Figure13 NTC Circuit

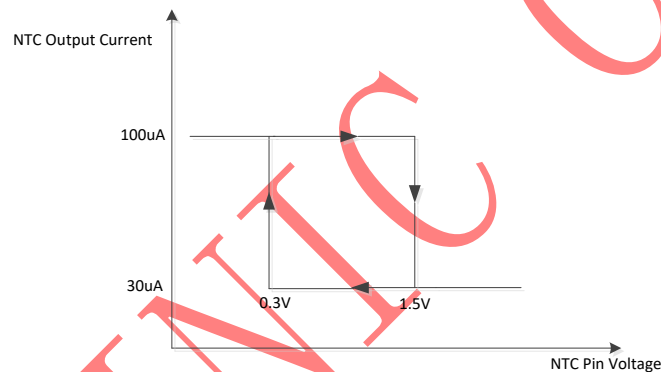

Figure14 Relationship Between NTC Voltage And Output Current

In order to better distinguish between high temperature and low temperature, NTC pin outputs 100uA current at high temperature and 30uA current at low temperature. When the NTC discharge current is 100uA, if the NTC voltage is higher than 1500mV, the current becomes 30uA. When the NTC discharge current is 30uA, if the NTC voltage is lower than 300mV, the current changes to 100uA.

In the state of charge:

When the NTC voltage is lower than 0.49V, it means the battery temperature is higher than 45 degrees; the charging is stopped.

When the NTC voltage is higher than 0.82V, it means the battery temperature is lower than 0 degrees; the charging is stopped.

In the state of discharge:

When the NTC voltage is lower than 0.30V, it means the battery temperature is higher than 60 degrees; the discharging is stopped.

When the NTC voltage is higher than 2.09V, it means the battery temperature is lower than -20 degrees; the discharging is stopped.

If NTC is not required in the scheme, the NTC pin shall be connected 10K to GND. Floating or direct grounding is not allowed.

Full Battery Voltage Setting

IP5333 can select the full battery voltage by configuring the VSET function on the GPIO2 pin by connecting different pull-down resistors.

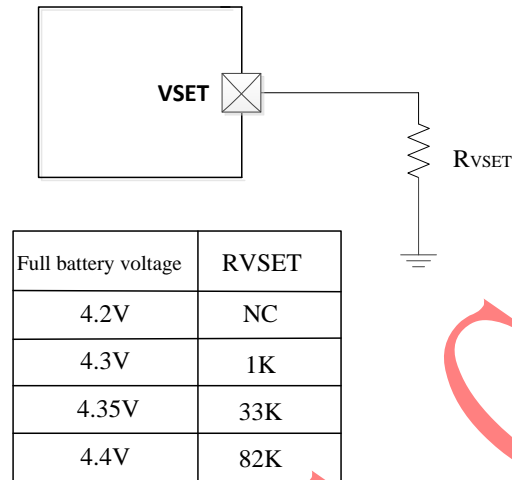

Figure15 Full Battery Voltage Setting Circuit

Charging Current Setting

IP5333 can select the constant charging current of VBUS port by configuring the ICHG function on the GPIO1 pin by connecting different pull-down resistors.

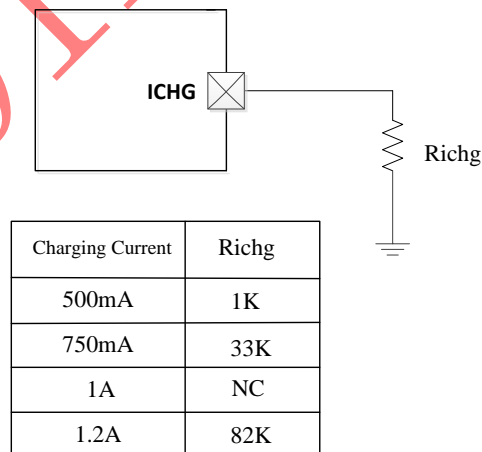

Figure16 Constant Charging Current Setting Circuit

Battery Capacity Setting

IP5333 can select the battery capacity by configuring the FCAP function on the GPIO0 pin by connecting different pull-down resistors.

* This function is only valid on IP5333_188 series.

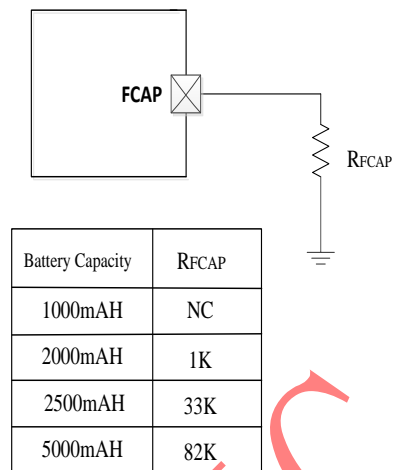

Figure17 Battery Capacity Setting Circuit

VCC

VCC is a normally opened 3.1V LDO. Load capacity is 30mA. External connect a 2.2uF capacitor to GND.

12 Typical Application Diagram

IP5333 only needs inductors, capacitors and resistors to realize the complete scheme of mobile power supply.

4LED mode typical application diagram

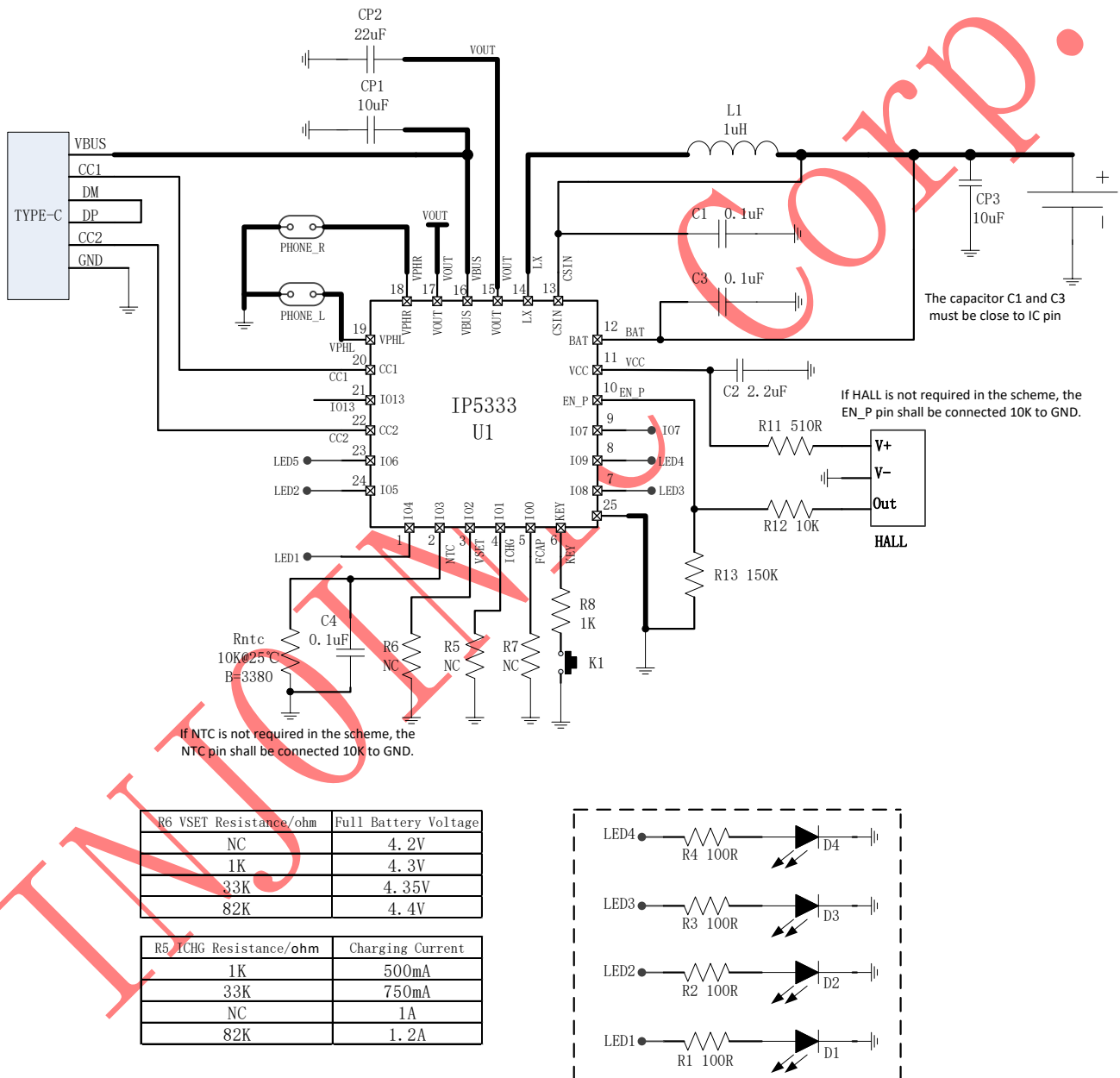

Figure18 IP5333 LED Typical Application Diagram Circuit

188 digital tube typical application diagram

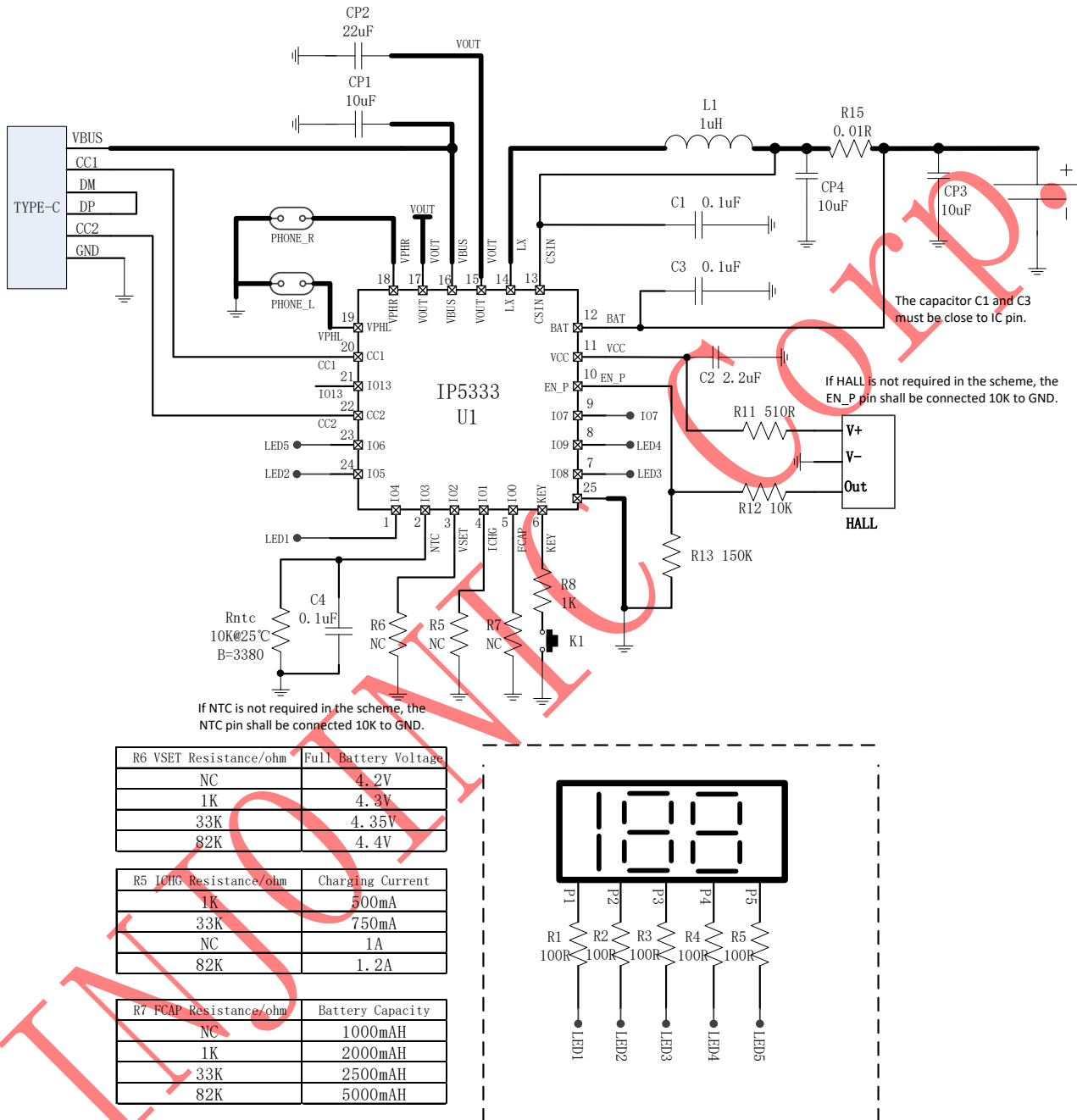
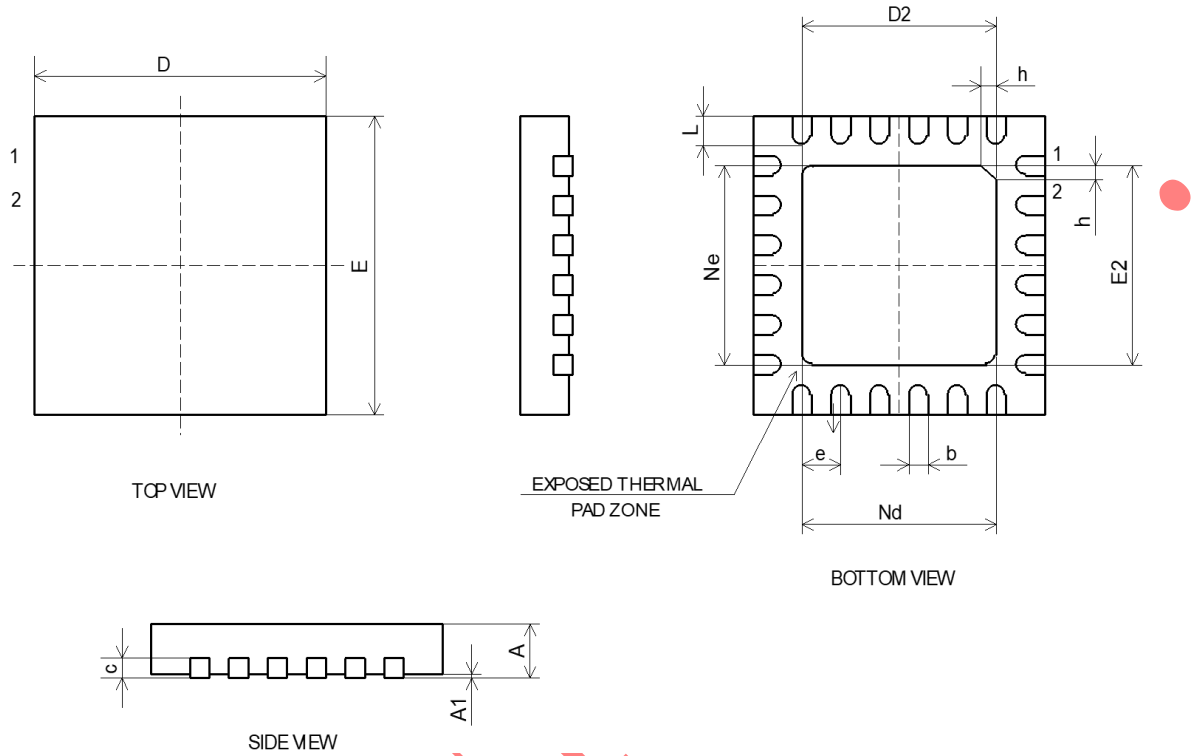

Figure19 IP5333 188 Typical Application Diagram Circuit

13 Package



SYMBOL	MILLIMETER		
	MIN	NOM	MAX
A	0.70	0.75	0.80
A1	-	0.02	0.05
b	0.18	0.25	0.30
c	0.18	0.20	0.25
D	3.90	4.00	4.10
D2	2.40	2.50	2.60
e	0.50BSC		
Ne	2.50BSC		
Nd	2.50BSC		
E	3.90	4.00	4.10
E2	2.40	2.50	2.60
L	0.35	0.40	0.45
h	0.30	0.35	0.40

14 IMPORTANT NOTICE

INJOINIC TECHNOLOGY and its subsidiaries reserve the right to make corrections, enhancements, improvements and other changes to its semiconductor products and services. Buyers should obtain the latest relevant information before placing orders and should verify that such information is current and complete. All semiconductor products (also referred to herein as “components”) are sold subject to INJOINIC TECHNOLOGY's terms and conditions of sale supplied at the time of order acknowledgment.

INJOINIC TECHNOLOGY assumes no liability for applications assistance or the design of Buyers' products. Buyers are responsible for their products and applications using INJOINIC TECHNOLOGY's components. To minimize the risks associated with Buyers' products and applications, Buyers should provide adequate design and operating safeguards.

Buyer acknowledges and agrees that it is solely responsible for compliance with all legal, regulatory and safety-related requirements concerning its products, and any use of INJOINIC TECHNOLOGY's components in its applications, notwithstanding any applications-related information or support that may be provided by INJOINIC TECHNOLOGY. Buyer represents and agrees that it has all the necessary expertise to create and implement safeguards which anticipate dangerous consequences of failures, monitor failures and their consequences, lessen the likelihood of failures that might cause harm and take appropriate remedial actions. Buyer will fully indemnify INJOINIC TECHNOLOGY and its representatives against any damages arising out of the use of any INJOINIC TECHNOLOGY's components in safety-critical applications.

Reproduction of significant portions of INJOINIC TECHNOLOGY's information in INJOINIC TECHNOLOGY's data books or data sheets is permissible only if reproduction is without alteration and is accompanied by all associated warranties, conditions, limitations, and notices. INJOINIC TECHNOLOGY is not responsible or liable for such altered documentation. Information of third parties may be subject to additional restrictions.

INJOINIC TECHNOLOGY will update this document from time to time. The actual parameters of the product may vary due to different models or other items. This document voids all express and any implied warranties.

Resale of INJOINIC TECHNOLOGY's components or services with statements different from or beyond the parameters stated by INJOINIC TECHNOLOGY for that component or service voids all express and any implied warranties for the associated INJOINIC TECHNOLOGY's component or service and is an unfair and deceptive business practice. INJOINIC TECHNOLOGY is not responsible or liable for any such statements.